

Continuous-Wave Fiber Laser
User Guide
RFL-C015H1-CE

武汉锐科光纤激光技术股份有限公司
Wuhan Raycus Fiber Laser Technologies Co., Ltd.

TABLE OF CONTENTS

1 Safety Information	4
1.1 Symbols Used in this User Guide	4
1.2 Laser Classification	4
1.3 Safety Labels	4
1.4 Optical Safety	6
1.5 Electrical Safety	6
1.6 Other Safety Rules	6
2 Product Description	7
2.1 Features	7
2.2 Package Contents	7
2.3 Unpacking and Inspection	7
2.4 Operation Environment	8
2.5 Precautions for Use	9
2.6 Specifications	10
3 Installation	11
3.1 Dimensions	11
3.2 Output Head and Installation	12
3.3 Cooling Requirements	12
3.4 Installation Procedure	14
4 Using the Product	16
4.1 Power Connection	16
4.2 CTRL-INTERFACE Definitions	16
4.3 Steps of shutting down	16
4.4 Laser intelligent connection system APP operation instructions	17
5 Instructions for use of switching power supply	26
5.1 Appearance structure and interface	26
5.2 Installation and Design	27
5.3 Fault diagnosis and troubleshooting	29
6 Common alarm and handling measures	30
6.1 Alarms Display	30
6.2 Alarm solutions	30
7 Warranty, Return and Maintenance	32
7.1 General Warranty	32
7.2 Limitations of Warranty	32
7.3 Service and Repair	32

8 End-of-life disposal..... 33

1 Safety Information

Thank you for choosing Raycus fiber laser. This User Guide provides important safety, operation, warranty and other information. Please read it carefully before you use this product. In order to ensure safe operation and optimal performance of the product, please follow the warnings, cautions, operating procedures and other instructions accordingly.

1.1 Symbols Used in this User Guide

	WARNING: Refers to a potential hazard that may leads to a personal injury or death.
---	--

	CAUTION: Refers to potential a hazard that may leads to general personal injury or product damage.
---	---

1.2 Laser Classification

According to the European Community standards EN 60825 - 1, clause 9, this series of lasers are classified as a high power Class 4. This product emits invisible laser radiation at wavelength of 1080 nm, and the light power is 100 -2000W up to machine. Direct or indirect exposure of high power of laser radiation may cause damage to the eyes or skin. Despite the radiation being invisible, the beam may cause irreversible damage to the retina and cornea. Appropriate and approved laser goggles must be worn all the time during the laser device is operating.

	WARNING: You must use appropriate laser safety eyewear when this device is operating. The laser safety eyewear is selected according to the range of wavelengths emitted from this product. The end user must ensure that the laser safety eyewear being used protects against light emitted by the device over its entire range of wavelengths. Please verify that the personal protective equipment (e.g. enclosures, viewing windows or viewports, eyewear, etc.) being utilized is adequate for the output power and wavelength ranges listed on the product.
---	--

1.3 Safety Labels

The position of the safety labels on products varies depending on the model of the continuous-wave fiber laser, as shown in Figure 1:

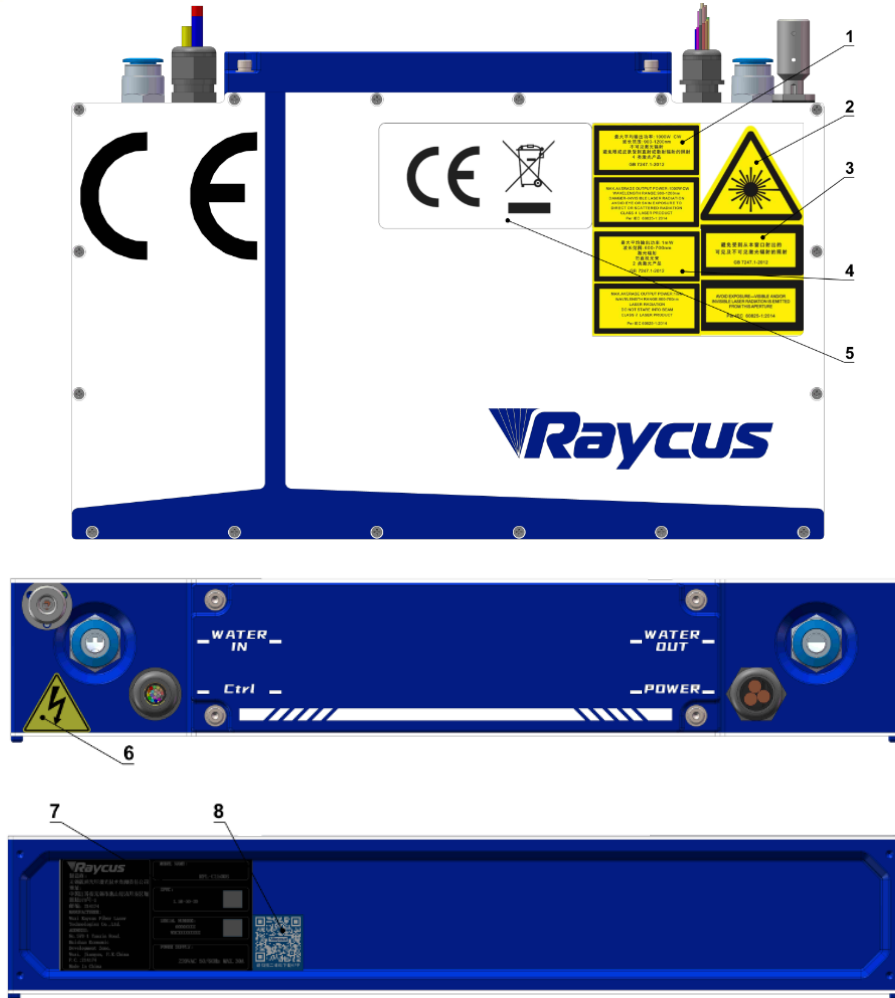

Figure 1 Safety Label Locations

These safety labels include warning labels, apertures through which laser radiation is emitted and labels of certification and identification, etc. Specifications of these labels are as follows:

Table 1 Specifications of Safety Labels

<p>1: Class 4 Laser Product</p>	<p>2: Laser Radiation Hazard Label</p>	<p>3: Laser Emit Head</p>	<p>4: Class 2M Laser Product Label for Guide Laser</p>
<p>5: CE Authentication</p>	<p>6: Identification Plate</p>	<p>7: Electrical Hazard</p>	<p>8: QR code label</p>

1.4 Optical Safety

Any dust on the end of the collimator assembly can burn the lens and damage the laser.

	<p>CAUTION: If the output of the device is delivered through a lens with an anti-reflection coating, make sure that the lens is of good quality and clean.</p>
---	---

1.5 Electrical Safety

- a) Make sure your product is grounded through the PE line of the AC power cord. The grounding must be firm and reliable.

	<p>WARNING: Any interruption from the protective earth will electrify the enclosure, which may result in personal injury.</p>
---	--

- b) Make sure that the correct voltage of the AC power source is used.

	<p>CAUTION: Failure to connect the correct voltage could damage the product.</p>
---	---

1.6 Other Safety Rules

- a) Never look directly into the laser output port when power is supplied to the laser.
- b) Avoid using the laser in a dim or darkened environment.
- c) If this device is used in a manner not specified in this document, the protection provided by the device may be impaired and the warranty will be voided.
- d) There are no operator serviceable parts inside, and all maintenance must be performed in Raycus or by qualified Raycus personnel. Do not try to remove covers, or electrical shock may be caused, and warranty will be void.

2 Product Description

2.1 Features

Compared with traditional lasers, Raycus CW fiber laser has higher efficiency electric-optical conversion, lower power consumption and excellent beam quality. The fiber laser is compact and ready to use. It can be used as a stand-alone unit or easily inserted into user's apparatus.

Main Features:

- a) Excellent beam quality
- b) High quality fiber output
- c) High Power Stability
- d) Continuously tunable output power, quick switching response
- e) Slow rise and slow fall, Waveform editing
- f) Maintenance free operation
- g) High wall plug efficiency

Applications:

- a) Welding, 5G, Infrastructure
- b) 3D Printing
- c) Scientific research

2.2 Package Contents

Please refer to the packing list accompanying the shipment to check actual items included.

2.3 Unpacking and Inspection

Raycus CW fiber laser is shipped in a package designed to provide maximum protection. Upon delivery, please inspect all packaging for evidence of mishandling or damage. If you find any evidence of mishandling, please save the damaged material and contact the shipping agent and Raycus immediately.

Remove all the contents from the packing case. Take extra care when removing the unit out of the packing case to ensure that the fiber optic cable is not twisted, hauled or damaged. A comprehensive packing list is included with the system documentation. Check all items against the list and contact Raycus immediately if there is any missing item or evident damage to the unit. DO NOT attempt to install or operate the laser, if there is any evident or suspected damage to the unit.

It is recommended to keep the packing materials, as they will be necessary if you ever need to ship the unit back for service at a later date.

	<p>CAUTION: The fiber optic cable and output head is precise optic instrument, any vibration or impact to the output head, and twist or excessive bend to the cable will damage the instrument.</p>
---	--

2.4 Operation Environment

The basic operation conditions are listed in the table below:

Table 2 Basic Operation Conditions for the Laser

Model	RFL-C015H1-CE
Supply Voltage(V)	40-80V DC
Supply Capacity(kW)	3.5
Installation Requirements	Install on flat surface, no vibration or impact
Ambient Temperature(°C)	10~40
Relative Humidity(%)	30~70

Warning:

- a) Ensure reliable grounded before using the laser.
- b) The laser output is connected to the output cable. Please check the laser output carefully to prevent dust or other contamination. Use special paper when cleaning the laser output lens.
- c) If the laser is used in accordance without the method specified in this manual, the laser may be in abnormal working state and cause damage.
- d) It is strictly forbidden to install the laser output when the laser is in operation.
- e) Do not look directly into the laser output. Be sure to wear protective glasses when operating the laser.

	<ul style="list-style-type: none"> ◆ Do not expose this product to high humidity (>95%) ◆ Do not let this product work below the ambient dew point temperature.
---	--

Table 3 The Constant Dew Point Table

AMBIENT DEW POINT									
Room Temperature(°C)	Maximum Relative humidity								
	20%	30%	40%	50%	60%	70%	80%	90%	95%
20	-3.5	2	6	9	12	14.5	16.5	18	19
25	0.5	6	10.5	14	16.5	19	21	23	24
30	4.6	10.5	15	18.5	21.5	24	26	28	29
35	8.5	15	19.5	23	26	28.5	31	33	34
40	13	20	24	27.5	31	33.5	36	38	39
			Laser operating temperature range						



- ◆ Green area: The dew point temperature is **22°C** that is lower than the laser cooling water temperature, which can be used safely;
- ◆ Red area: If the dew point temperature is higher than 22°C and exceeds the laser cooling water temperature by 22°C, there must be dew condensation, and measures must be taken.
Measure : Installing cabinet air conditioner to reduce ambient.

2.5 Precautions for Use

- a) Before supplying the power to the device, make sure that the correct voltage of the AC power source is used. Faulty voltage connections can damage the device.
- b) Failure to follow the instructions may cause malfunction and damage to the device, such damage is not covered by warranty.
- c) It is very important to ensure the cleanness of the calibrated laser output head, otherwise it will cause irreparable damage to the laser.
- d) Please inspect the output head carefully for dust or other contamination. Use appropriate lens paper to clean it if necessary. Do not touch the output lens at any time; as well as remember to cap the output head when it is not in use, and make sure the cap is clean.
- e) Failure to follow the specified instructions may result in the loss of laser power, and such loss will not be covered by the warranty.

2.6 Specifications

Table 4 Specifications

No.	Items	Conditions	Indicator Value	Unit	Notes
Optical Specifications					
1	Operation Modes	/	CW/Modulated		
2	Nominal Output Power	Cooling water temperature 22±1°C	1200±50	W	
3	Power Adjust Range	/	2-100	%	Resolution 1%
4	Emission Wavelength	Nominal Output Power	1080±5	nm	
5	Output Power Instability	Nominal Output Power	<±1	%	
6	Modulation Frequency	Nominal Output Power	1-5000	Hz	Resolution 1Hz
7	Duty Cycle Range	Nominal Output Power	1-100	%	Resolution 1%
8	Red Guide Laser Power	630-650nm	0.5-1	mW	
Optical Output Characteristics of IQB head					
9	Fiber Core Diameter	/	25	um	
10	Numerical Aperture	/	0.07	/	
11	Beam Quality(M2)	25um Fiber Core Diameter	≤1.8		
12	Delivery Cable Length	/	10	m	Customizable length
Other Characteristics					
13	Operating Voltage	/	40-80	VDC	
14	Control Mode	/	Control line/Bluetooth		
15	Max. Power Consumption	/	<3.5	kW	
16	Photoelectric Conversion Efficiency	Nominal Output Power	>33%		
17	Dimensions	W×D×H	370×215×68	mm	
18	Switching power supply size	W×D×H	135×368×50	mm	
19	Switching power supply weight	/	3±1	kg	

3 Installation

3.1 Dimensions

Figure 2 shows the external dimensions of the shows dimensions of RFL-C015H1-CE.

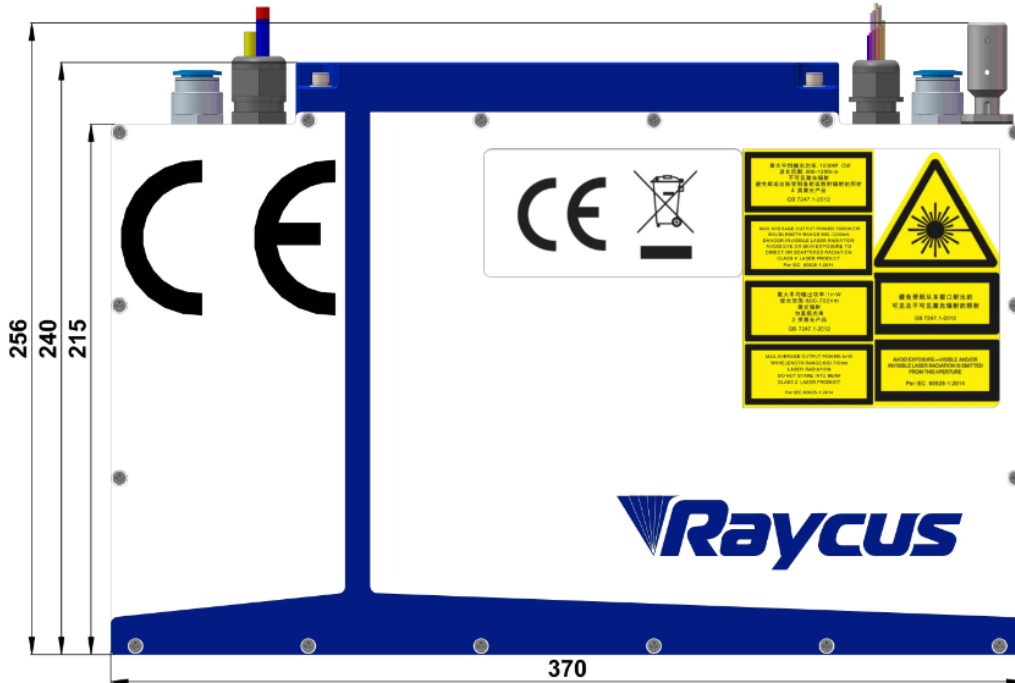

Figure2 (a) Top panel view (unit: mm)

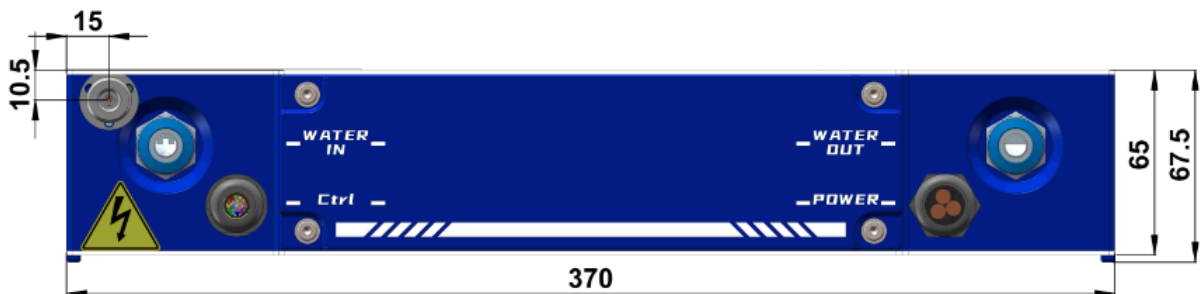

Figure2 (b) Rear panel view (unit: mm)

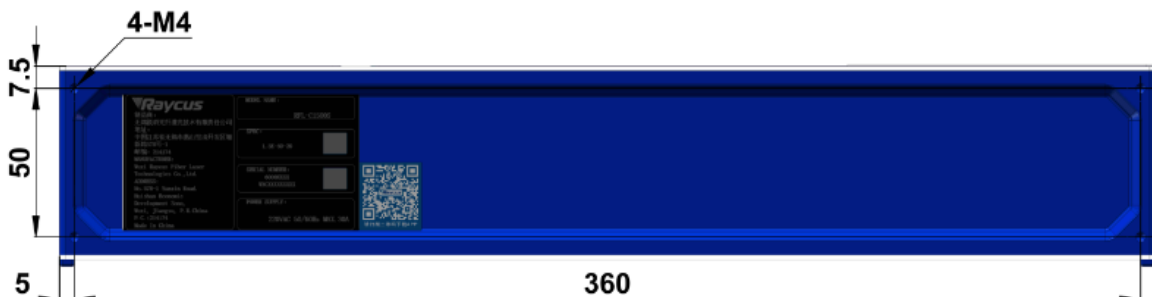

Figure2 (c) Front panel view (unit: mm)

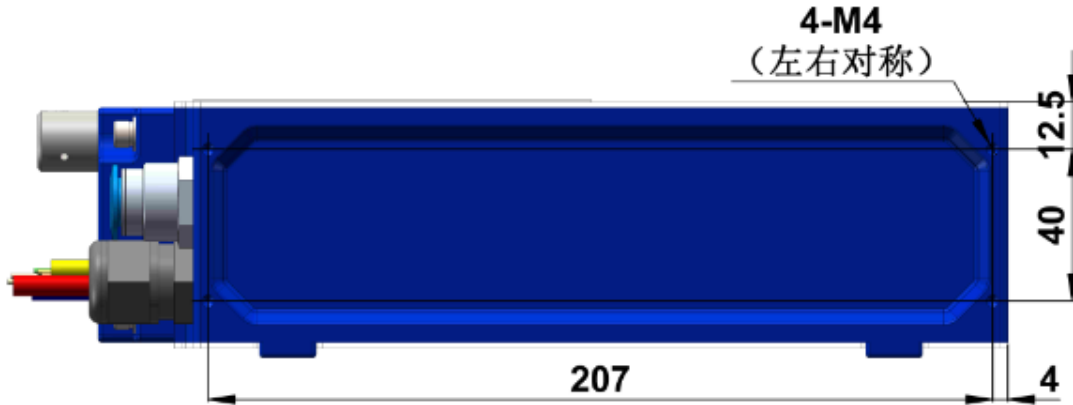

Figure2 (d) Side panel view (unit: mm)

3.2 Output Head and Installation

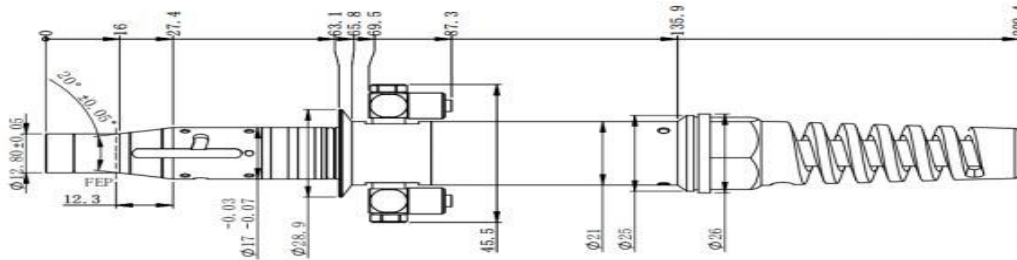

Figure 3 Dimensions of IQB Output Head (unit : mm)

The IQB laser output head of are all the standard IQB interface. The specific appearance and dimensions are shown in Figure 3 above.

	<p>CAUTIONS:</p> <ul style="list-style-type: none"> ◆ Inspect the output lens before installing the output head to the processing head. Clean the output lens if necessary. ◆ It is strictly prohibited to disassemble the output head by personnel not approved by Raycus, or the warranty is void.
--	---

3.3 Cooling Requirements

Table 5 Cooling Requirements

型号	RFL-C015H1-CE
Cooling Capability(W)	>2400
Minimum Flow(L/min)	16
Maximum Pressure(Bar)	7
Pipe Inner Diameter(mm)	12
Water temperature of cooling system(°C)	22±1°C

- a) The water temperature setting of cooling system: 22 ± 1°C
- b) Cooling water requirements:
 - 1) It is recommended to use purified water.

- 2) In order to prevent the growth of mold that may lead to pipe blockage, we recommend to add alcohol about 10% of the total volume.
 - 3) If the product is used in an environment that ambient temperature is between -10°C and 0°C , we recommend to use 30% alcohol, and replace it every two months.
 - 4) If the product is used in an environment that ambient temperature is below -10°C , please use dual-system chillers (with heating function) and ensure uninterrupted operation of the cooling system.
- c) Requirements for output cable cooling system:
- 1) Rate of liquid flow: 1.7-2.0 L/min;
 - 2) Pressure of liquid flow: < 0.6 MPa at the inflow;
 - 3) Type of liquid exchange junction: SMC MS-5H-6;
 - 4) Type of tube: outer diameter 6; inner diameter 4;
 - 5) Direction of cooling liquid: unidirectional; connect the tube with the water-pipe strictly according to direction shown on the layer of the tube;
 - 6) Type of liquid: deionized water, condensed water, pure water;
 - 7) PH value of liquid: 5.5 - 9;
 - 8) Filter is needed for the cooling system, and the size of the solid residual practicals should be within 100um;
 - 9) Maximum temperature of liquid: 45°C ;
 - 10) Minimum temperature of liquid: greater than the saturated dew-point 5°C ;
 - 11) Additive to the liquid: satisfies the requirements of PH value and size of solid residual practicals as above;
 - 12) Radius of the bending of the armored pipe: off-work state (i.e. transportation and reservation): minimum diameter of bending ≥ 20 cm; in-work state: minimum diameter of bending ≥ 30 cm;
 - 13) Long-term vibration < 2 G; Impact action < 10 G.
- d) Other requirements for chiller:
- 1) When starting the cooling system for the first time, check the entire water system and the joint for water leakage. The external water pipe must be installed and connected according to the inlet (IN) and outlet (OUT) by the laser. Otherwise, the laser may not work properly.
 - 2) If you will not use the laser for a long time, water must be emptied from the product, and then both the inlet and outlet must be blocked with the nuts we provide. Failure to do so may lead to permanent equipment damage.

	<p>CAUTION: Please set the water temperature in strictly accordance with the requirements above. Too low temperature may lead to condensation on the laser module and the output cable. This can cause serious damage to the equipment.</p>
---	--

	<p>CAUTION: Make sure that the water temperature reaches the set point and the cooling system is working well before you start the laser. ($22 \pm 1^{\circ}\text{C}$)</p>
---	--

3.4 Installation Procedure

- a) Place the product in a still and stable position.
- b) Check if the power supply has the correct voltage (See Table 4 for the laser model and corresponding input voltage), and the earth line is connected, make sure it is firm and reliable.
- c) Connect the power cable and control cable to the product when power supply is OFF.
- d) Insert the water pipes into the inlet and outlet.
- e) Check the output head and clean it if necessary. This procedure must be performed by personnel of Raycus or authorized by Raycus. Make sure the environment is clean, or the output cable may be contaminated.
- f) Prevent the delivery cable from treading, pinching or excessive bending during installation.
- g) During the installation and disassembly process, please take care to handle the laser output head gently, avoiding any shock.
- h) In the installation of laser output cable and output head process, please make sure that the surrounding environment is clean, otherwise it may pollute the output head (do not use fans, which actually may bring more dust).
- i) The minimum bending radius of the output fiber cable of the laser should not be less than 20 cm under the non-working conditions, and the minimum bending radius should not be less than 30 cm when the laser is working.

	<p>CAUTION: ◆ All the cables can only be connected when power supply is OFF. Hot plug may damage the laser.</p>
---	--



CAUTION:

- ◆ The laser output optical cable should be kept as natural as possible and not be distorted.
- ◆ The too small bending radius of the output fiber cable will damage the laser.



CAUTION:

- ◆ Make sure the aperture and the cavity of the processing head is clean.
- ◆ Keep the protective cap properly, prevent it from contamination; Or the aperture will be contaminated when capped.

4 Using the Product

4.1 Power Connection

Table 6 Power Connection Requirements

Model	RFL-C015H1-CE
Supply Source	40-80 V DC
Power Cord	The laser comes with a 1.5-meter power cord
One End of Power Cord	Three wires labeled +, -, PE

4.2 CTRL-INTERFACE Definitions

Table 7 Control interface definition

PIN No.	Line Mark	Name	Description		Level
1	ITL-A/1	Interlock A	Short circuit	Passive contacts must not be connected to external voltage or ground	
2	ITL-B/2	Interlock B			
3	AD/3	Analog	Input	External analog, 0-10V corresponds to 0-100% optical output power	0-10V
4	AD-GND/4	EGND	Circuit end	Analog input circuit end	0V
5	MOD+/5	MOD+	Input	Laser modulation signal	24V
6	MOD-/6	MOD-	Circuit end	Modulation signal loop terminal	0V
7	Red-Laser/7	Guide laser On	Input	Red light control	24V
8	ALARM/8	Scatter Err Out	Output	Laser alarm (High level alarm)	-
9	EXT-24VIN/9	Main control board power supply	Input	Main control board power supply	24V
10	24V-GND/10	24V-GND	Loop terminal	Temperature alarm	
11	EXT-24VIN/11	Contact closure input	Short circuit	Activates the internal control system power supply in REM mode. Passive contact, not connected to external voltage or grounding.	
12	+24V/12				
13	PE/13	PE	PE	Shield	

4.3 Steps of shutting down

Please turn off the laser in the order below:

- a) Turn off the emission;
- b) Disconnect the laser AC;
- c) Turn off the chiller;
- d) Cover the output head protection cap;

4.4 Laser intelligent connection system APP operation instructions

4.4.1 Log in

After opening the Laser intelligent connection system APP, the account and password login page are displayed, as shown in Figure 4:

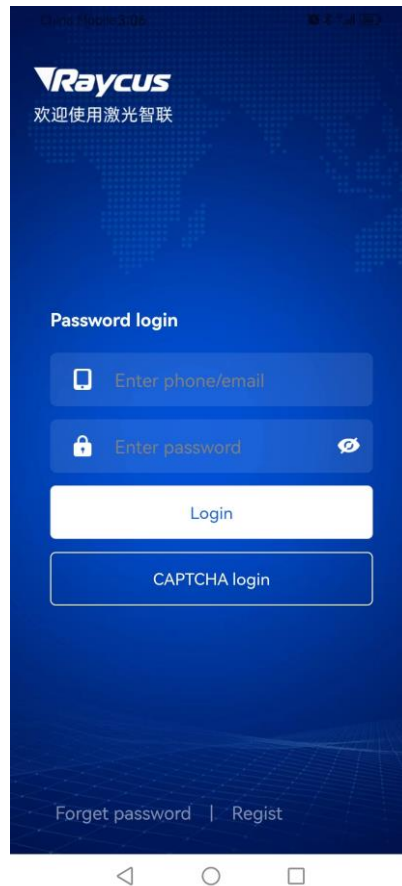

Figure 4 Log in interface

4.4.2 Connect

Enter the login screen, enter the mobile phone number and password, and then click Log in, log in successfully. The connection page to the APP is shown in Figure 5:

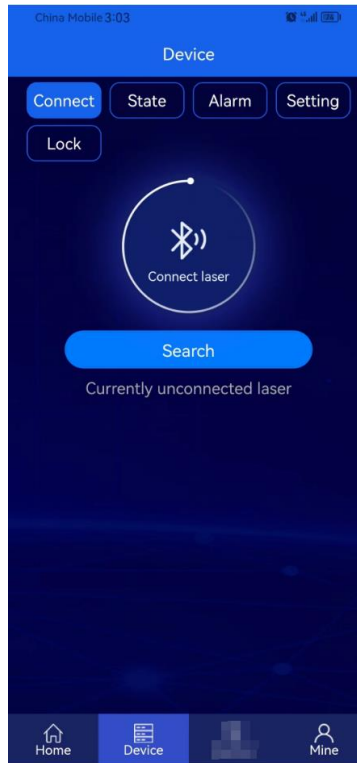

Figure 5 Verification code login page

Turn on the Bluetooth switch of the single-mode laser APP. If there is a Bluetooth device nearby, ensure that the Bluetooth is set Switch on the standby, click the "Search" button on the connection page.



Figure 6 Connection

Click "Connect" on the right of the searched Bluetooth device to enter the state of connection, as shown in Figure 7 sign:

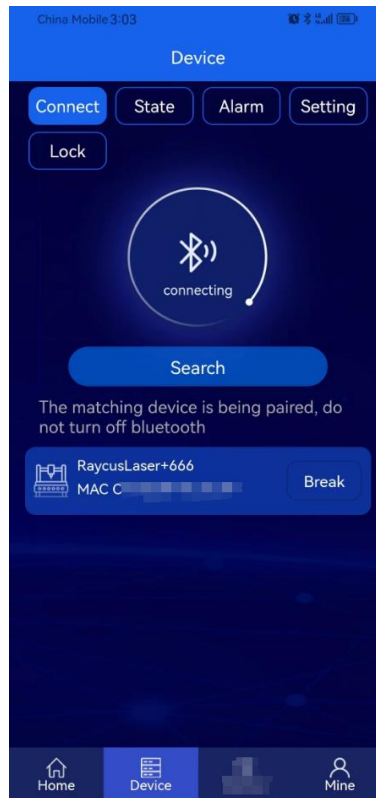

Figure 7 Connecting

4.4.3 Equipment

After successful connection, the laser device-status interface is displayed, as shown in Figure 8:

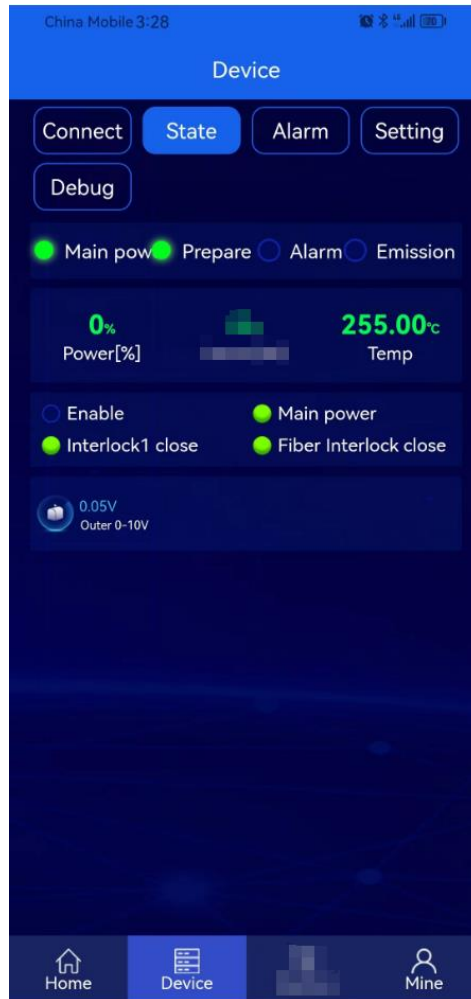

Figure 8 Device - Status

The device status page mainly has the main power supply, equipment, alarm, light status display, and light. The state display of percentage, light output power, laser temperature, as well as the state display of emergency stop, REM, laser enable, red light, as well as the specific state of the laser and some parameter values.

There is also the Device-Alarm page, if the laser is not in the alarm state after the laser is connected, the screen displays "No alarm, go to check the history!" If there is an alarm status, the specific title of the alarm will be displayed, as shown in Figure 9, 10:

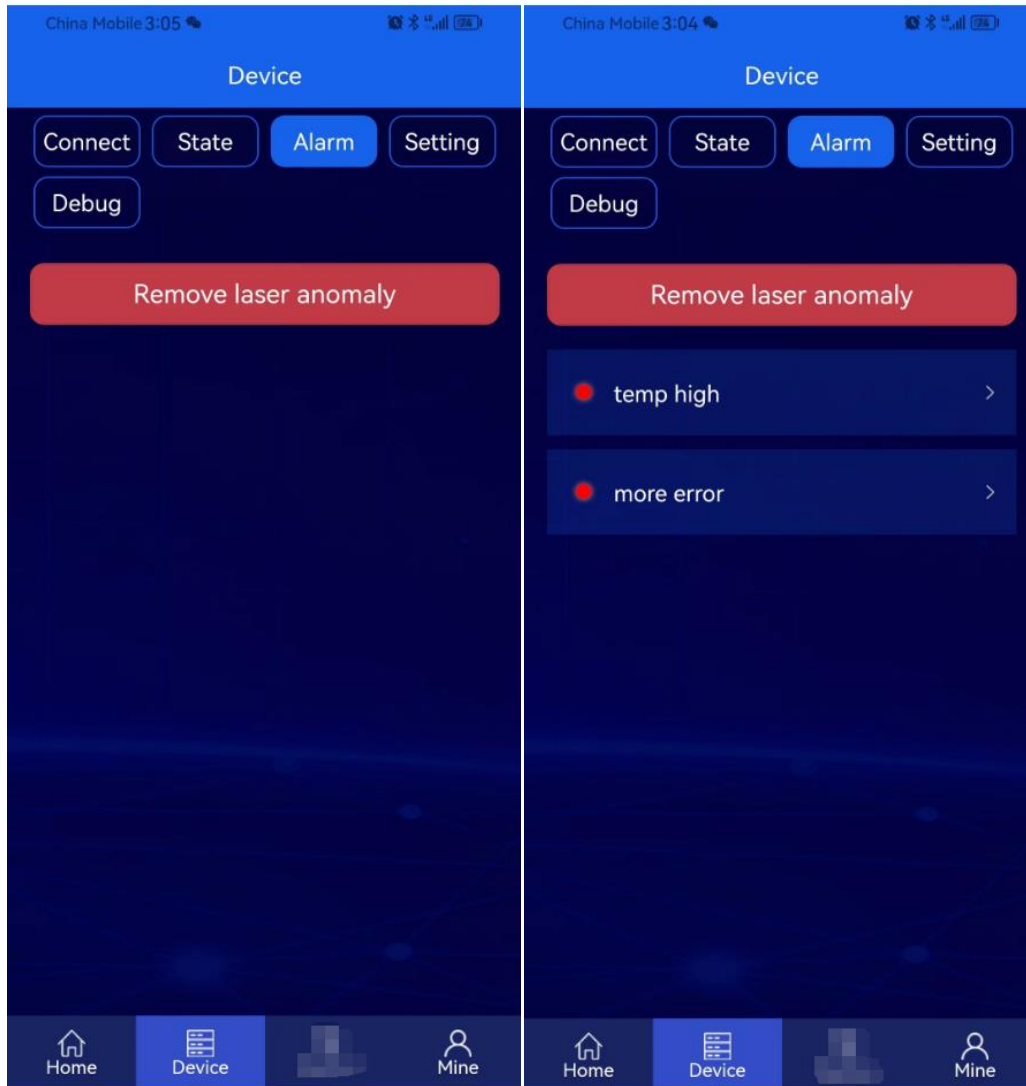

Figure 9 /10 Device – Alarm (No alarm content & Specific title)

The status display of the laser also has the function of supporting the setting of some parameters, which can be seen in the device-setting interface, as shown in Figure 11:

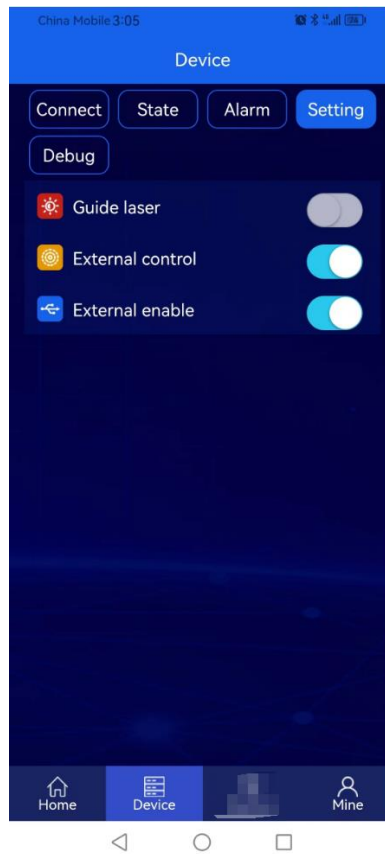

Figure 11 Devices – Settings

4.4.4 Mine

Entering Mine – About us, you can see function introduction, version update, and about machines, as shown in Figure 12:

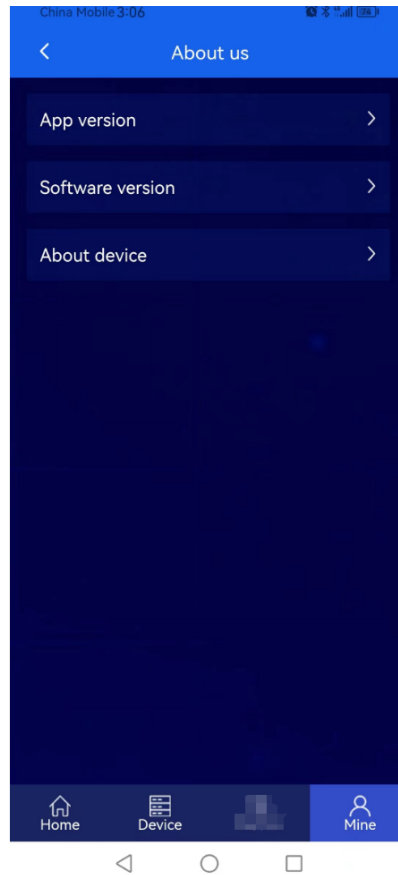

Figure 12 Mine – About us

The APP version information interface displays the current version information and upgraded version of the laser. As shown in Figure 13:

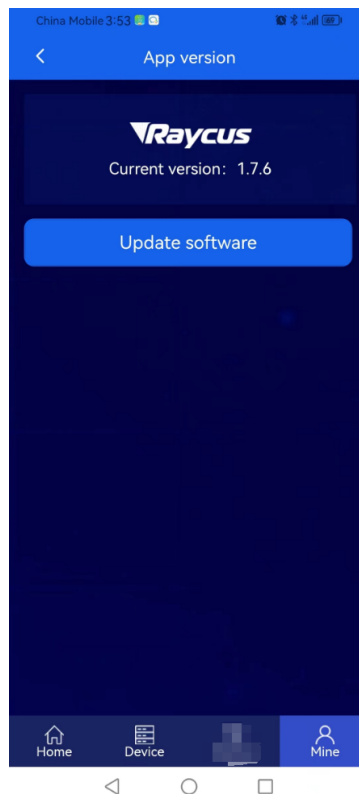

Figure 13 Mine - About us – App version

Mine - About the machine page shows the relevant information of the laser, such as laser time, laser model, laser serial number, main control serial number, key version number, system information. As shown in Figure 14:

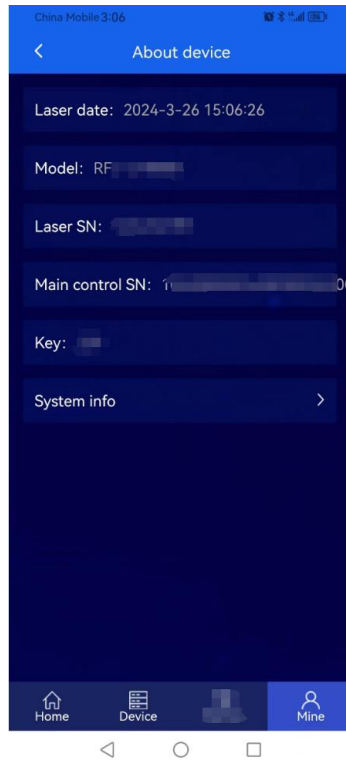

Figure 14 Mine - About device

In Mine - About machine - System Information page, and laser detailed information. As shown in Figure 15:



Figure 15 Mine - About device – System info

4.4.5 Software introduction

The Laser intelligent connection system APP is a mobile software that can be connected to the laser through Bluetooth to facilitate the after-sales, maintenance, and commissioning engineers, etc., without portable notebooks, you can use the single -mode laser app installed on Android phones to and the laser. Connect, read the state of the laser or set some parameters, which is conducive to the rapid, effective and convenient solution to some problems in the use of laser use.

4.4.6 Workflow

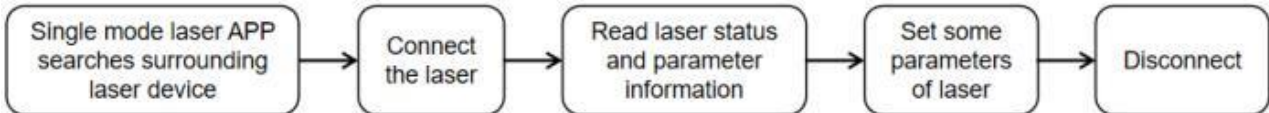

Figure 16 The process of the APP

5 Instructions for use of switching power supply

5.1 Appearance structure and interface

5.1.1 Appearance structure

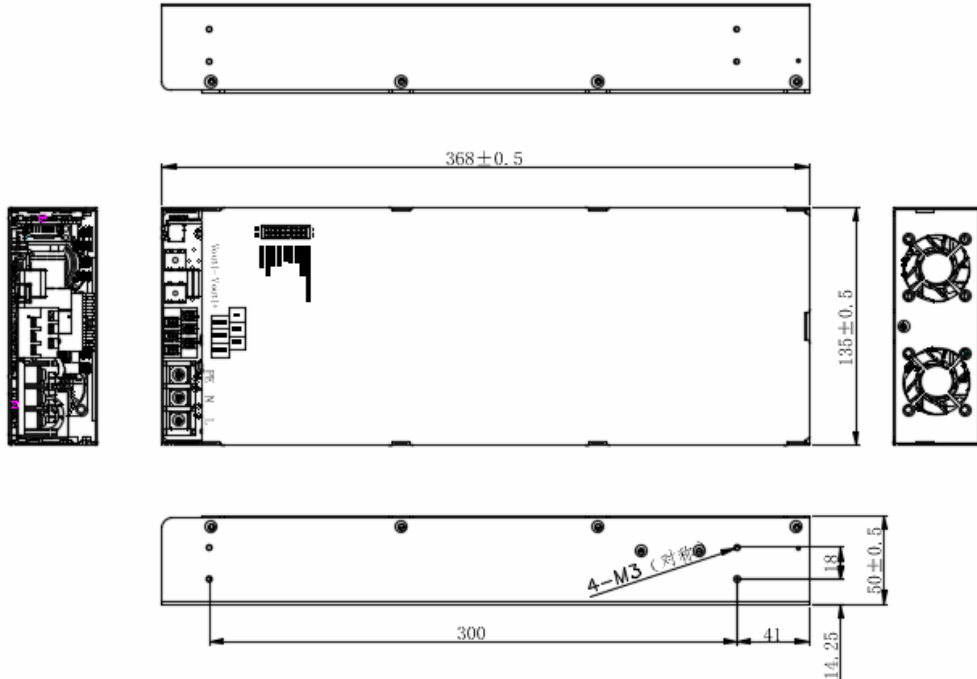

Figure 17 The size of the switch power supply

5.1.2 Input/output interfaces

The input and output of the switching power supply and the various signal ports are connected through the socket at the back, and the terminal types and pins are defined as follows:

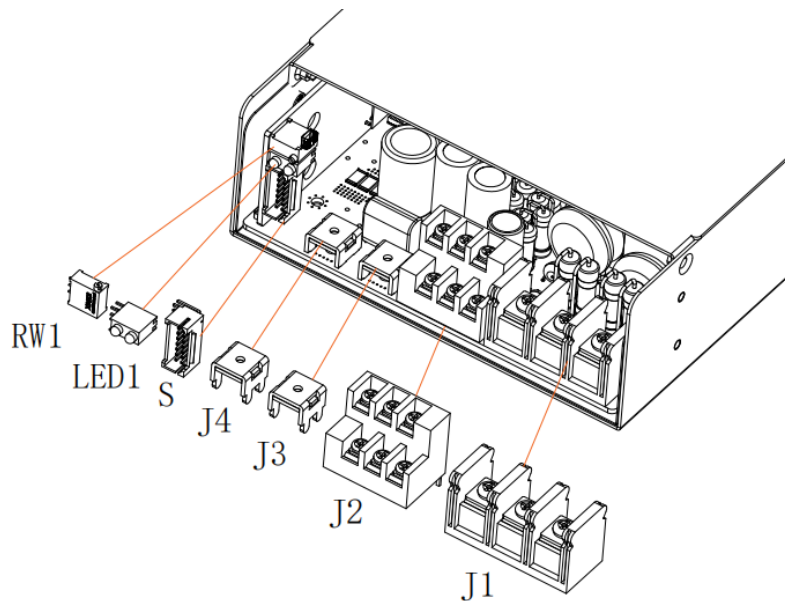
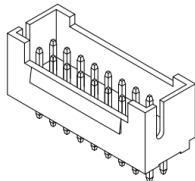
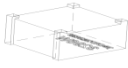

Figure 18 The schematic diagram of the switch interface

Table 8 The interface definition of the switching power supply

Tag Number	Port Name	Port Specifications and Models	Pin Identification	Function Description	
J1	AC Input	BA8-03-13.0-00-C	PE	Protective Ground	
			N	AC input neutral line	
			L	AC input live wire	
J3、J4	DC Output	MT44005D	Vout1+	Main output voltage positive terminal	
			Vout1-	Main output voltage negative terminal	
J2		DA1.5-03-7.62-00	48VGND	48V output voltage negative terminal	
			48V	48V output voltage positive terminal	
			24V1GND	24V1 output voltage negative terminal	
			24V	24V output voltage positive terminal	
			24V2GND	24V2 output voltage negative terminal, 独立地	
			+24V2	24V2 output voltage positive terminal	
S		Alarm/C ontrol Terminal	 A2008H-2x8P	1、2、3: NC	NC
				4、10: GND	GND
	5: CANH			Communication port, fixed 120Ω±1.5Ω matching resistor	
	6: CANL				
	7: +24V2			Auxiliary source power supply	
	8: 24V2GND				
	9: AUX+5V			5V output positive, maximum output current 50mA, reference 485GND	
	11、12: NC			NC	
	13、14: Ready			V1 status signal, refer to 485GND. After the power supply receives ON and the self-check is normal, it outputs a high level within 2 seconds; When the power self-check fails after receiving ON, output a low level within 3 seconds; After AC input, when the power supply fails, it directly outputs a low level.	
	15: ON/OFF			Power on/off control signal, reference 485GND low level: V1 start high level or suspended: V1 close	
16: NC	NC				
RW2	Adjust the potentiometer		—	Main output voltage regulation	

Attention:

- a) For safety, make sure that the PE side of the protective ground in the AC input is properly connected to the ground.
- b) In order to ensure the reliability of the system, the single-phase AC input of each module must be independently configured with an incoming air switch.

5.2 Installation and Design

5.2.1 Schematic diagram of the installation of the power supply

The power module can be installed horizontally and sideways, and cannot be installed vertically (upright along the length of the module).

The following is a reference installation diagram:

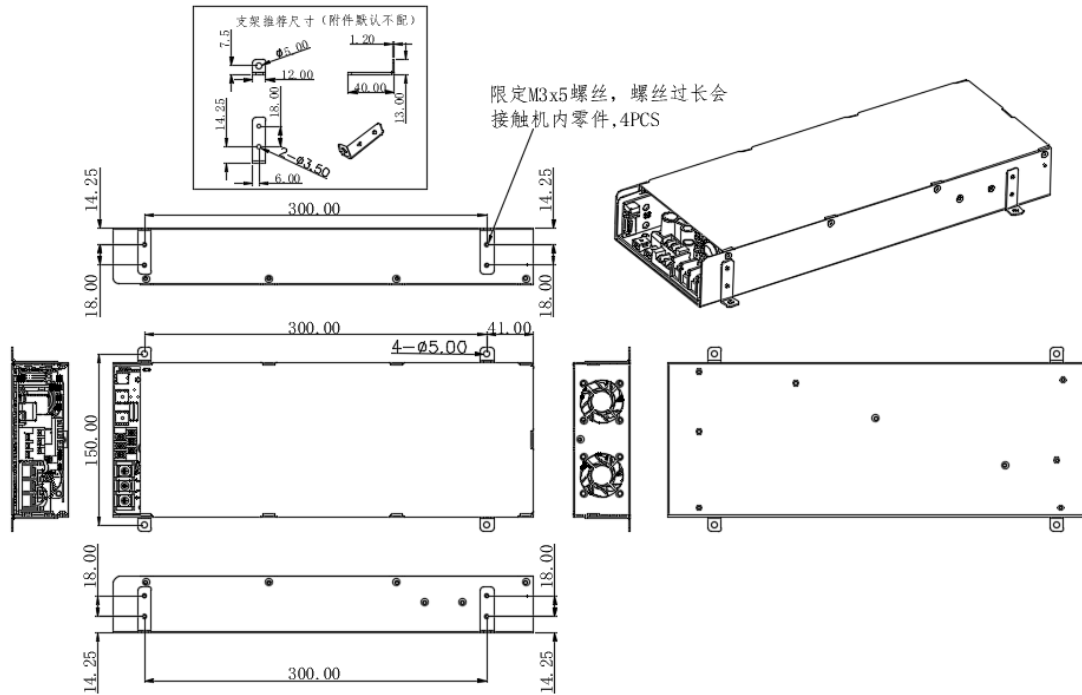

Figure 19 Module Horizontal- Small Bracket Installation Reference Diagram (Unit: mm)

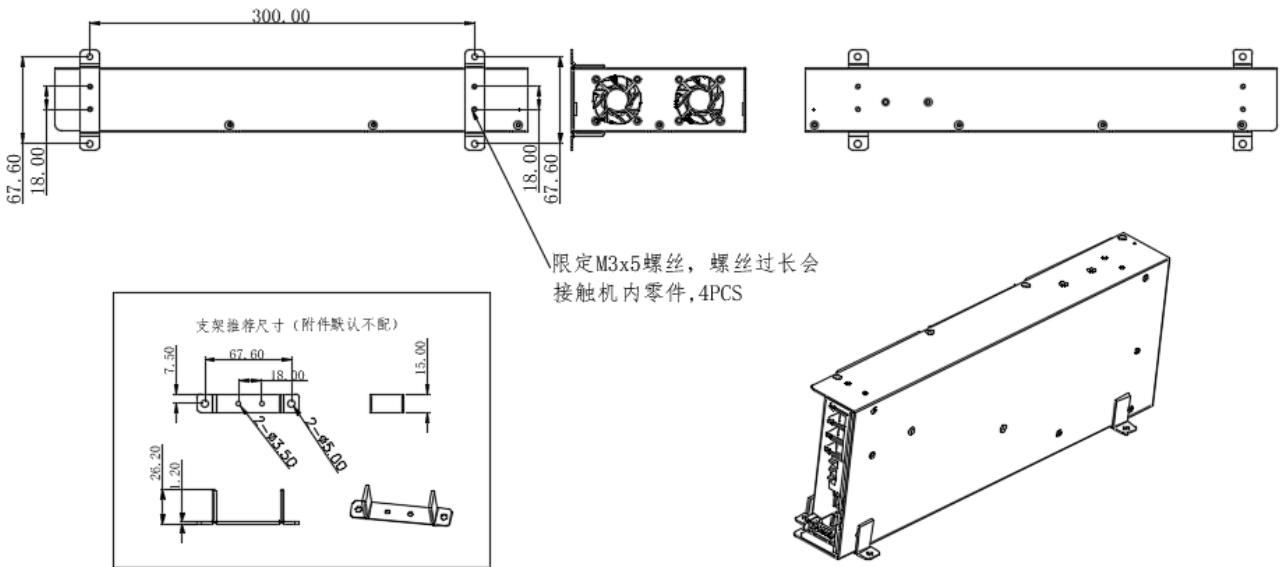

Figure 20 Module Side Vertical- Small Bracket Installation Reference Diagram (Unit: mm)

5.2.2 Module heat dissipation requirements

When designing the system, it is necessary to ensure that there is more than 10cm air inlet space at the front end of the module panel, and ensure that there is a smooth air inlet and a smooth air outlet

at the tail of the module. The temperature of the air outlet is about 10 °C higher than that of the air inlet, so the design of the module tail system avoids the installation of temperature- sensitive devices as much as possible.

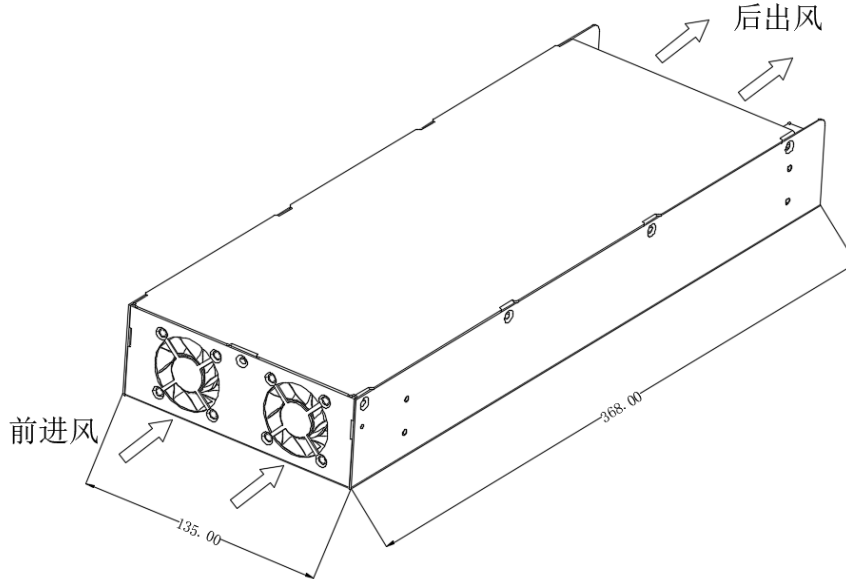

Figure 21 Reference diagram of module heat dissipation

Attention:

To design a cabinet, consider the design of the air duct for heat dissipation of the module.

5.2.3 Module usage environment requirements

- a) Working Temperature: $-15^{\circ}\text{C}\sim+45^{\circ}\text{C}$
- b) Storage Temperature: $-40^{\circ}\text{C}\sim+85^{\circ}\text{C}$
- c) Relative Humidity: $\leq 95\%$ non-condensing
- d) Altitude: $\leq 3000\text{m}$
- e) Atmospheric pressure: $70\sim 106\text{KPa}$

5.2.4 Module installation instructions

Table 9 Module installation instructions

Mounting hole location	Recommended screw models	Maximum penetration depth	Recommended installation torque
Mounting holes on the side of the power supply	M3	4mm	7-11Kgf-cm

5.3 Fault diagnosis and troubleshooting

The remote control signal given by the rectifier module is normal, the external connection cable is correct, and the output of the module is still abnormal, please disconnect the AC power supply immediately, remove the input/output/signal cable of the rectifier module, remove the fixing screw of the module, remove the rectifier module, and replace the backup module with the backup module if there is a backup module.

6 Common alarm and handling measures

6.1 Alarms Display

Connect Bluetooth, after the laser and the client software to establish normal communication. All alarm states of the laser can be displayed on the software interface, as shown in Figure 16. When the internal temperature of the laser is abnormal, Alarms are generated when the output power, scattered light, or power supply is abnormal.

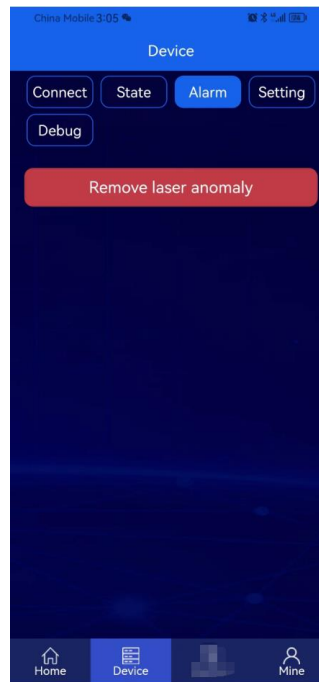

Figure17 The homepage of the client-ware

When the laser is running, when any alarm occurs (except Interlock exception), the Bluetooth interface will also display the alarm.

6.2 Alarm solutions

The instructions and solutions of alarms are as follows:

Table 10 Instructions and solutions for alarms of laser

Alarm name	Alarm instructions and solutions
Interlock Alarm	<p>Instruction: Occurs when the Interlock is disconnected.</p> <p>Solution: Short the Interlock pins and restart the laser to try. If this error continues to occur, please contact Raycus.</p>
Laser Out Alarm	<p>Instruction: 1. Laser Out Alarm immediately occurs when the laser is powered.</p> <p>Solution: The laser will auto-lock after two times of this error occurs successive, please contact Raycus.</p> <p>2. The laser will get this error when it does not emit with correct settings.</p> <p>Solution: Close the shutter and pop up the “LASER” button on the front panel of the laser to check if the red guide light is output normally when it isn’t emitting. If there is no red guide light, please stop using the laser immediately and contact Raycus. If the red guide light output normally, please restart the laser to try, if the alarm continues to occur, please contact Raycus.</p>
Laser Power Alarm	<p>Instruction: The alarm is generated when the emission of the laser cannot reach the set value. Power error occurs only when the laser is emitting.</p> <p>Solution: Restart the laser, if this error continues to occur, please contact Raycus.</p>
T1/T2 Alarm	<p>Instruction: Low temperature/high temperature alarm of the laser. The sensor in the laser detects an abnormal temperature inside the laser. A high-temperature / low-temperature error occurs when the temperature at the monitoring point exceeds the set upper / lower limit.</p> <p>Solution: High temperature alarm, please check if the water-cooling system is normally working, the water temperature is set correctly, and the water connection is correct. When the water cooling system works normally and the water temperature drops below 30 ℃, restart the laser. If the alarm continues, please contact Raycus.</p>
Hum Alarm	<p>Instruction: The Hum Alarm of the laser, the internal temperature of the laser detects that the current water-cooled plate temperature is lower than the internal dew point temperature, and there is a risk of condensation.</p> <p>Solution: Immediately stop using the laser. For RFL-C100~RFL-C1000, please improve the working environment and after the ambient temperature is lower than internal temperature of the laser, restart the laser (advice to configure alone Air-conditioned room for the laser). For RFL-C100~RFL-C1000, please wait for the air conditioner to run for 30 minutes before restart the laser. If the alarm continues to occur, please contact Raycus.</p>

In addition to the above, if there are any questions or errors in using of the laser, you can contact Raycus to get help.

7 Warranty, Return and Maintenance

7.1 General Warranty

Raycus warrants that all Raycus fiber laser products are conformed to applicable product specifications under normal use and are free from defects in materials and workmanship. The warranties start on the date of shipment from Raycus for a period of time as set forth in the applicable purchase contracts or product specifications. Raycus has the right to choose to repair or replace any product that proves to be defective in materials and workmanship selectively during the warranty period. Only products with particular defects are under warranty. Raycus reserves the right to issue a credit note for any defective products produced in normal conditions.

7.2 Limitations of Warranty

The warranty does not cover the maintenance or reimbursement of our product of which the problem results from tampering, disassembling, misuse, accident, modification, unsuitable physical or operating environment, improper maintenance, damages caused by those who are not from Raycus due to excessive use or not following the instructions. Customer has the responsibility to understand and follow this instruction to use the device. Any damage caused by fault operating is not warranted. Accessories and fiber connectors are excluded from this warranty.

According to the warranty, client should write to us within 31 days after the defect is discovered. This warranty does not involve any other party, including specified buyer, end-user or customer and any parts, equipment or other products produced by other companies.

	<p>◆ It is the customer's responsibility to understand and follow operating instructions in this User Guide and specifications prior to operation-failure to do so may void this warranty. Accessories and fiber connectors are not covered by this warranty.</p>
---	---

7.3 Service and Repair

- a) Do not open the device. There are no user serviceable parts, equipment or assemblies for user in this product. All service and maintenance shall be performed by qualified Raycus personnel.
- b) Please contact Raycus as soon as possible when problems under warranty about maintenance happened to the product.
- c) The product returned with permission should be placed in a suitable container.
- d) If any damage happened to the product, please notify the carrier in document immediately.

8 End-of-life disposal

When the laser device reaches the service life or has serious and cannot be transformed or repaired, or meets other scrapping conditions stipulated by safety technology, it can be scrapped and recycled, and the recycling treatment shall meet the “Regulations on the Recycling and Disposal of Waste Electrical and Electronic Products” .

We reserve the right to make changes in design or constructions of any of our products at anytime without incurring any obligation to make changes or install the same on units previously purchased.

All the items about warranty and service above provided by Raycus are for user’s reference; formal contents about warranty and service are subject to the contract.