



Continuous-Wave Fiber Laser User Guide for RFL-C30000M~C40000M V1.0

Wuhan Raycus Fiber Laser Technologies Co., Ltd.

CONTENTS

1 Safety Information	1
1.1 Security Label.....	1
1.2 Laser Safety Grade	2
1.3 Optical Safety	3
1.4 Electrical Safety.....	3
1.5 Other Safety Rules.....	3
2 Product Description	5
2.1 Features.....	5
2.2 Package Parts	5
2.3 Unpacking and Inspection	5
2.4 Operation Environment	6
2.5 Attentions.....	6
2.6 Features.....	7
3 Installation	7
3.1 Dimensions	7
3.2 Installation Rule.....	10
3.3 Protective End Cap of Output Cable and Using Description	12
3.3.1 Types of Protective End Caps and Factory Status.....	12
3.3.2 Pre-installation Cleaning Instructions for Output Cables.....	13
3.4 Cooling Requirements	16
4 Using the Product	18
4.1 Front Panel.....	18
4.2 Rear Panel.....	20
4.3 Power Connection.....	21
4.4 Control Interface Definition	22
4.4.1 Safety XP2 Interface.....	23
4.4.2 HARDWIRING XP1	24
4.4.3 Serial RS232 Interface	26
4.4.4 Analog Interface XP4	27
4.4.5 ETHERNET Interface XP5	27
4.5 Introduction to Safety Interlock.....	27
4.6 Start Operation Sequence	28

5 Control Mode Selection.....	28
5.1 ON Mode	30
5.2 AD Enable Mode	30
5.3 Emission External Control Enable.....	30
5.4 Guide Laser (Red Guide Beam) Control	30
5.5 Programming Mode	30
5.6 REM Mode	31
5.6.1 AD Enable Mode	31
5.6.2 Emission External Control.....	31
5.6.3 Red Light Control.....	31
5.6.4 Programming Mode	32
6 Laser Wiring Diagram and Operation Steps.....	32
6.1 Internal Control in ON Mode	32
6.2 Laser Operating in External Control Mode	33
6.3 In ON Mode, the Laser Emission Power is Externally Controlled by Analog Signal.....	34
6.4 Laser Operating in External Control Programming Mode	35
6.5 Set the Power Analog Quantity in REM Mode to Control the Laser Emission	36
6.6 Power Communication Setting in REM	37
6.7 Programming Mode in REM Mode.....	38
7 RS232 and ETHERNET Communication Command.....	39
7.1 Port Configuration	39
7.2 Laser Communication Protocol (Network Port & Serial Port).....	39
8 The instructions of Raycus software.....	44
8.1 The main menu of the Raycus computer software display	44
8.2 Selecting the laser	45
8.3 Selection of Raycus software working mode	46
8.4 Language Selection.....	46
8.5 About	47
8.6 Main status display area.....	48
8.6.1 Laser operation status display area	48
8.6.2 Display area for accumulated working time of laser	49
8.6.3 Laser power on, mode selection, light output control area.....	50
8.6.4 Slow rise and slow fall parameter area	51
8.6.5 Programming mode test area	51

8.6.6 Output parameter reading and setting area	51
8.7 Laser circuit status display area	52
8.8 Laser module enable display area.....	52
8.9 XP1 Interface Status Indication	53
8.10 Log.....	53
8.10.1 Downloading Historical Fault Records	53
8.10.2 Downloaded file address.....	54
8.11 Alarm Type Display Area.....	54
8.12 Module parameters (in diagnostic mode)	55
8.13 Programming mode (waveform editing)	55
8.13.1 Viewing the number of waveform bars inside the current laser.....	56
8.13.2 Viewing Waveform Content.....	56
8.13.3 Clear All Waveforms	56
8.13.4 Editing Waveform	57
8.13.5 Command Interpretation.....	59
9 Warranty, Repair and Return.....	62
9.1 General Warranty.....	62
9.2 Limitations of Warranty	62
9.3 Service and Repair.....	62

1 Safety Information

Thank you for choosing Raycus Fiber Laser. This user manual provides you with important safety, operation, maintenance and other relevant information. Please read the manual carefully before using this product. To ensure safe operation and optimum product operation, please observe the following cautions and warnings as well as other information within this manual.

1.1 Security Label

Security label of laser includes safety warning, fiber head warning, product certification, product trademark, etc. The location of safety signs is shown in the Figure 1

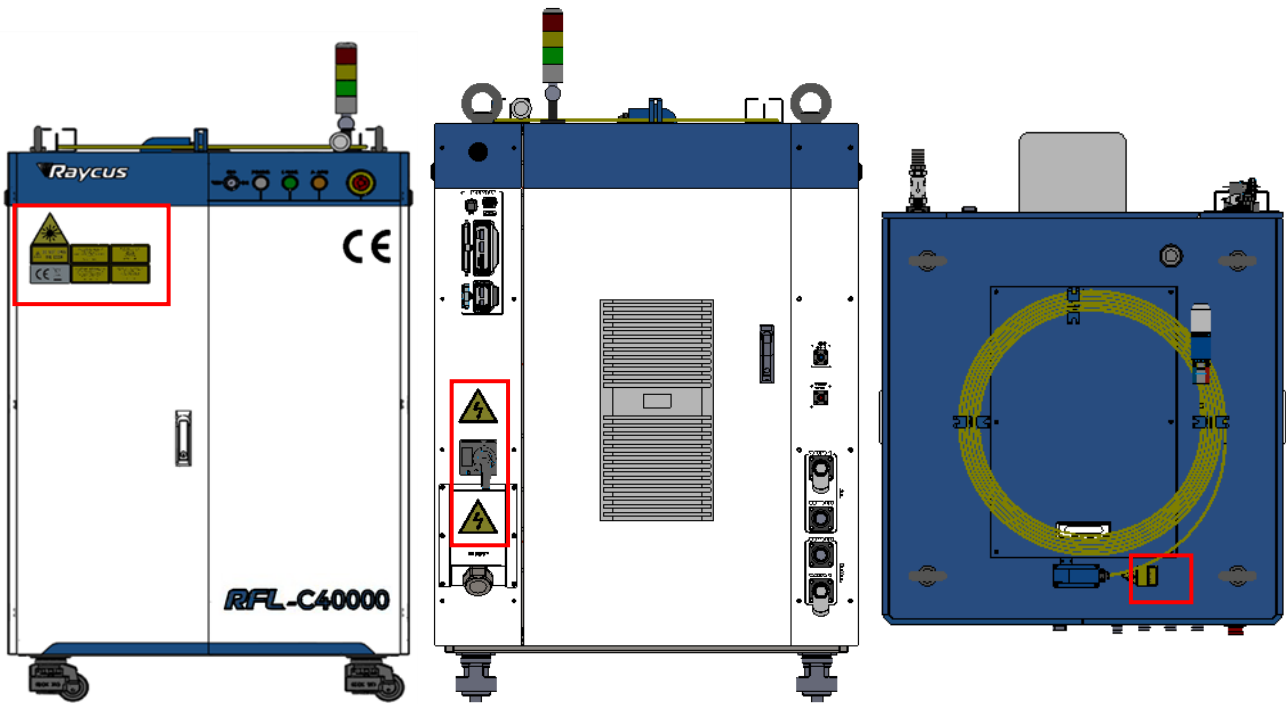

(a) RFL-C40000M-CE







(b) QP fiber head

Figure 1 Schematic diagram of the distribution location of laser safety signs

	WARNING: Describes a hazard that leads to severe injury or death to people.
--	--

	<p>CAUTION: Describes a hazard that leads to general injury to people or damages to product.</p>
---	---

<div data-bbox="201 450 501 595"> <p>AVOID EXPOSURE VISIBLE AND/OR INVISIBLE LASER RADIATION IS EMITTED FROM THIS APERTURE Per GB 7247.1-2012/IEC 60825-1:2007</p> </div> <p>English</p> <div data-bbox="201 674 501 819"> <p>激光窗口 避免受到从本窗口射出的 激光辐射的照射 GB 7247.1-2012/IEC 60825-1:2007</p> </div> <p>Chinese</p>	<div data-bbox="632 450 922 595"> <p>MAX AVERAGE OUTPUT POWER:4000W CW WAVELENGTH RANGE:900-1200nm DANGER-VISIBLE AND/OR INVISIBLE LASER RADIATION AVOID EYE OR SKIN EXPOSURE TO DIRECT OR SCATTERED RADIATION CLASS 4 LASER PRODUCT Per IEC 60825-1:2014</p> </div> <p>English (40000W)</p> <div data-bbox="632 674 922 819"> <p>最大平均输出功率:4000W CW 波长范围:900-1200nm 可见及不可见激光辐射 避免眼或皮肤受到直射或散射辐射的照射 4类激光产品 GB 7247.1-2012/IEC 60825-1:2007</p> </div> <p>Chinese (40000W)</p>	<div data-bbox="1106 450 1406 595"> <p>MAX AVERAGE OUTPUT POWER:5mW WAVELENGTH RANGE:600-700nm LASER RADIATION AVOID DIRECT EYE EXPOSURE CLASS 3R LASER PRODUCT Per IEC 60825-1:2014</p> </div> <p>English</p> <div data-bbox="1106 674 1406 819"> <p>最大平均输出功率:5mW 波长范围:600-700nm 激光辐射 避免眼睛受到直接照射 3R类激光产品 GB 7247.1-2012</p> </div> <p>Chinese</p>
<p>1:Laser Emit Head</p>	<p>2: Type 4 Laser Product</p>	<p>3: Class 3R Laser Product Label- 5mW Red Laser</p>
<div data-bbox="201 1010 472 1155">  </div>	<div data-bbox="632 994 962 1167">  </div>	<div data-bbox="1106 1016 1254 1144">  </div>
<p>4: CE Authentication</p>	<p>5: ID Label (40000W)</p>	<p>6: Laser Radiation Hazard</p>
<div data-bbox="201 1245 328 1368">  </div> <p>7:Electrical Hazard</p>		

1.2 Laser Safety Grade

According to European Standard EN 60825-1, Clause 9 and Chinese Standard GB 7247.1-2012 Safety of Laser Products Part 1:Equipment Classification Requirements, this series of lasers are Class 4 laser instruments. The product emits laser radiation at a wavelength of 1080 nm or around 1080 nm. Direct or Indirect exposure to high power laser radiation causes damage to the eye or skin. Although the radiant laser is not visible, the beam will cause irreparable damage to the retina or cornea, so appropriate and certified laser safety glasses must be worn throughout the laser emitting.



WARNING: Users must use appropriate laser goggles when operating this device. The laser goggles should be selected according to the range of wavelength emitted from this product. Users must ensure that the protect range of laser goggles over the entire range of laser wavelengths. Please **DO NOT** directly view the laser output head when laser emitting.

1.3 Optical Safety

Any dust on the end of the collimator assembly can damage the crystal of output head or the entire laser device.



CAUTION: **DO NOT** emit when the protective cap is not removed, otherwise the lens or crystal will be damaged.

1.4 Electrical Safety

- a) Ensure that the PE line is effectively grounded, and the installation environment is safe and reliable.



WARNING: The disconnection of the product grounding will electrify the enclosure, which may result in personal injury to the operator.

- b) Ensure that the AC voltage is supplied normally.



CAUTION: Wrong wiring mode or power supply voltage will cause an unrecoverable damage to the laser device.

1.5 Other Safety Rules

- a) Do not view the laser output head directly when laser is emitting.
- b) Do not use fiber lasers in dark or dim environments.
- c) If this device is used in a manner not specified in this document, the protection provided by the device may be impaired and the warranty will be voided.

- d) It is not allowed to operate the output head or the cutting head when the tricolor green light is on;
- e) There are no user serviceable parts, equipment or assemblies inside the product. All service and maintenance shall be performed conducted by a certified Raycus engineer. In order to prevent electric shock, please do not break the seal or uncover the shield. Failure to comply with this instruction will be treated as invalid warranty.

2 Product Description

2.1 Features

Fiber lasers are more compact and ready to use than conventional laser structures, with higher electrical and optical conversion efficiency, lower power consumption and better beam quality. Thanks to its flexible laser output, it can be easily integrated with system equipment.

Main Features:

- High beam quality
- High reliable
- Free-maintenance operation
- High electro-optical conversion efficiency
- Convenient control menu
- Fast modulation

Applications:

- Industrial cutting and welding
- Scientific research

2.2 Package Parts

Please refer to package accessories in the packing box.

2.3 Unpacking and Inspection

Through the specially designed packaging materials and cabinets, Raycus ensures that the lasers are fully protected during transportation. Nevertheless, in order to prevent unpredictable situations during transportation, the users still need to carefully check whether the package is correctly placed before unpacking, and there is no damage from phenomenon such as collision, cracking and flooding on the outside of the box. Once you find that there is an abnormality in the external cabinet, please inform Raycus Company in time to deal with it as soon as possible.

Please double check if each listed content is inside the package; and contact Raycus as soon as possible if there are any issues.

Take extra care when removing the unit from the package and make sure that the fiber optic cable stays away from any possible collision and vibration. Please DO NOT distort, bend or pull the output cable when unpacking the device; and avoid any collision to the head of laser output.



CAUTION: The fiber optic cable and output head are precise optic instrument, ANY vibration or impact to the output head, and twist or excessive bend to the cable will damage the instrument.

2.4 Operation Environment

The operation conditions are listed as the Table 1.

Table 1 The operation environment conditions for the laser

Type	RFL-C30000M-CE				RFL-C40000M-CE			
Supply voltage (V)	Three-phase four-wire system AC 323V~AC 437V, 50/60Hz (including PE)							
Power supply capacity (kVA)	> 120				> 150			
Water cooling parameter	TOP		BOTTOM		TOP		BOTTOM	
	Water cooling flow (L/min)	Pressure fall (Bar)	Water cooling flow (L/min)	Pressure fall (Bar)	Water cooling flow (L/min)	Pressure fall (Bar)	Water cooling flow (L/min)	Pressure fall (Bar)
	>110	1.5	>110	1.5	>125	1.5	>165	1.5
Ambient Temperature	10°C ~ 40°C							
Relative Humidity	< 70%							

- a) Make sure the product is properly grounded before use.
- b) The laser output head is connected with fiber optic cable. Please inspect the output head carefully for dust or other contaminations. Use appropriate lens paper to clean it if necessary.
- c) Failure to follow the instructions when operating the laser may cause malfunction and damage.
- d) It is not allowed to install the output head when the laser is in operation.
- e) Do not look into the output head directly. Wear appropriate protective eye glasses all the time when operating the laser.

Tips: Install the laser in an air-conditioned environment for longer life and better performance.

2.5 Attentions

- a) Make sure that the correct voltage of 380VAC is used. Connecting failure of power supply will damage the device.
- b) The output laser is collimated by the collimating lens, it is important to keep the collimating lens clean, otherwise it will damage the device.
- c) Please cap the output head when it is not in use. Do not touch the output lens at any time. Use appropriate lens paper to clean it if necessary.

- d) Safety keep the cap when using the laser. To avoid dust, make sure the opening direction of the cap is put down.
- e) Failure to follow the instructions may cause laser power loss, such loss is not covered by warranty.

2.6 Features

The optical, electrical and other properties of RFL-C30000M/40000M-CE lasers are listed in Table 2.

Table 2 Product technical data sheet

Optical properties		
Type	RFL-C30000M-CE	RFL-C40000M-CE
Output Power(kW)	30kW	40kW
Operation Mode	CW/Modulated	
Polarization State	Random	
Output Power Range (%)	10~100	
Emission Wavelength (nm)	1080±5 (Nominal Output Power)	
Output Power Unstability	±1.5% (Nominal Output Power; Duration: 5hrs; Ambient Temp: 22±1°C)	
Modulation Frequency (Hz)	50~5k	
Red Guide Laser Power(mW)	2~3	
Fiber output Type	QP	
Beam Quality (BPP, mm•mrad)	3.4-4.3 (Nominal Output Power)	3.4-4.5 (Nominal Output Power)
Fiber core diameter (µm)	100, 150(Customizable)	
Delivery Cable Length (m)	30 (Customizable)	
Electrical characteristics		
Operating Voltage	Three-phase four-wire system AC 323V~AC 437V、50/60Hz (Include PE)	
Maximum power Consumption (kW)	<90	<120
Control Method	Serial communication / AD/ Ethernet	
Other characteristics		
Dimension W×H×D (mm) (Includes casters and rings, without warning lights)	970×1700×1410	1145×1700×1445
Weight (kg) (Includes air conditioning)	<950	<1100
Operating Ambient Temperature (°C)	10~40	
Humidity (%)	<90	
Storage Temperature (°C)	-10~60	
Cooling Method	Water cooling	

3 Installation

3.1 Dimensions

The main body dimensions of RFL-C30000M-CE continuous fiber laser are shown in Figure 2.

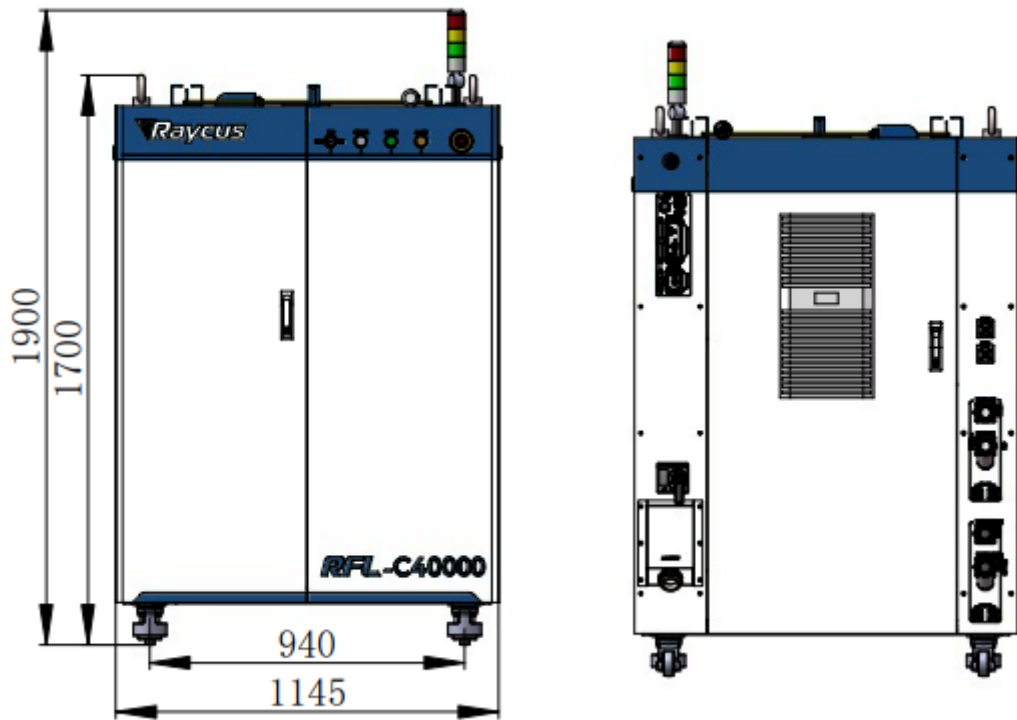

(a) Front view

(b) Rear view

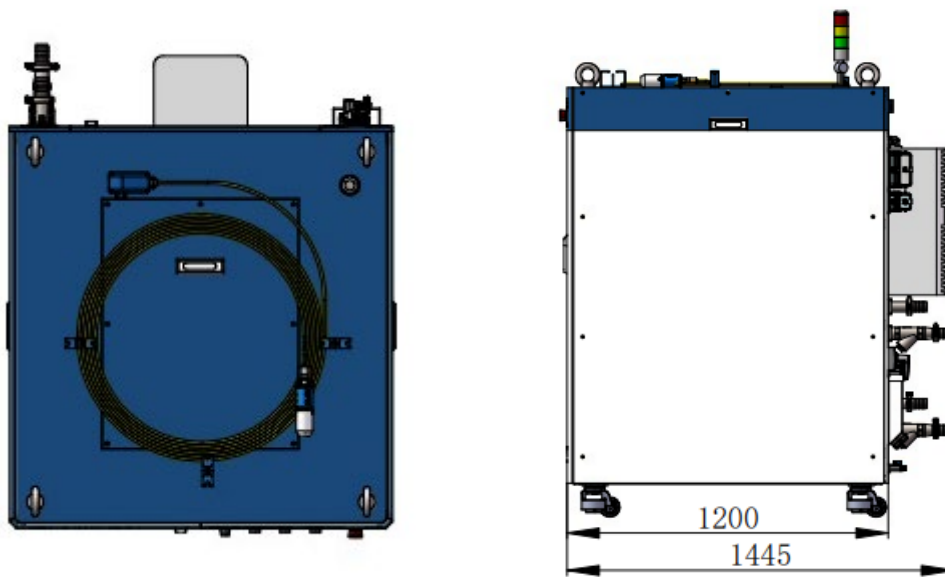

(c) Top view

(d) Left view

Figure2 The dimensions of RFL-C30000M-CE continuous fiber laser

The structure size of RFL-C30000M-CE laser is 970×1700×1410mm (width×height×depth; including casters and rings, without warning light); RFL-C30000M-CE laser weighs less than 950kg.

The main body dimensions of RFL-C40000M-CE continuous fiber laser are shown in Figure 3.

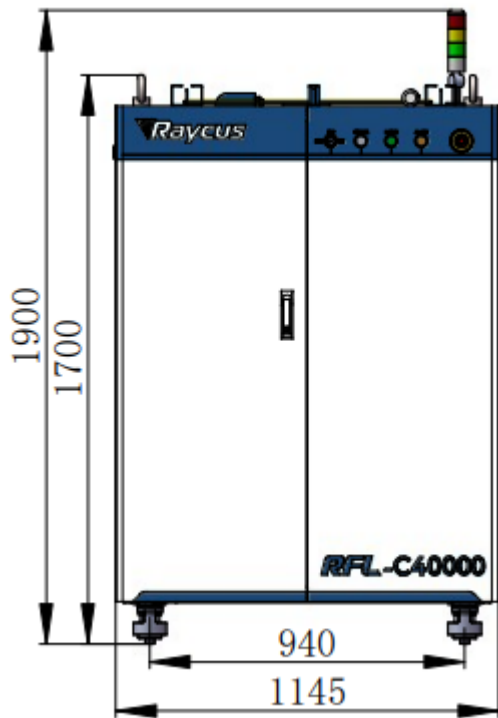

(a) Front view

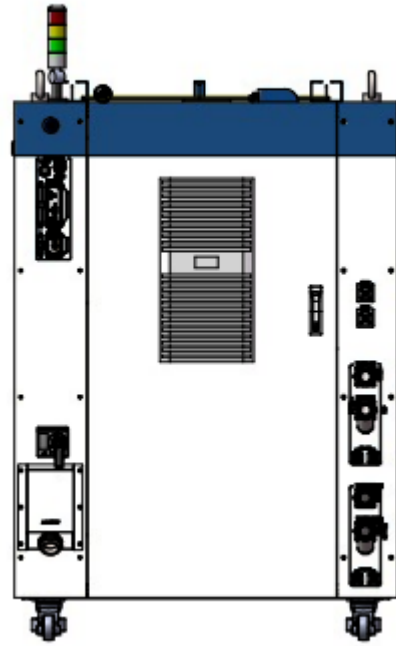

(b) Rear view

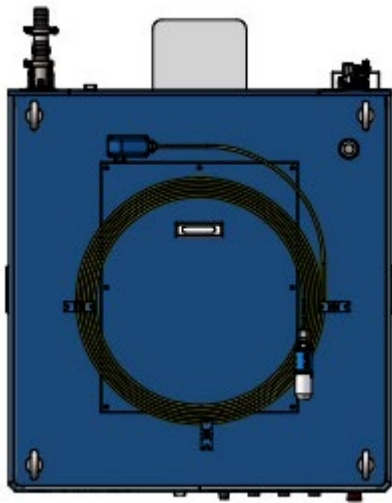

(c) Top view

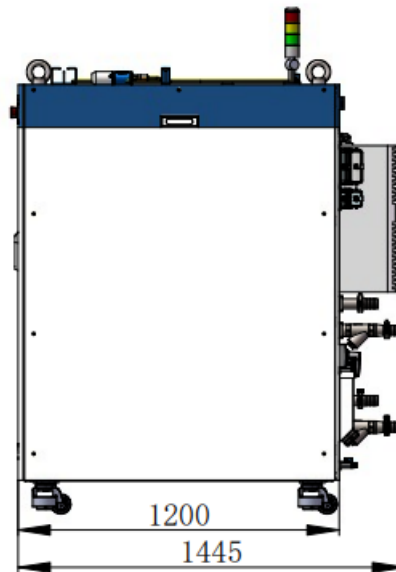

(d) Left view

Figure3 The dimensions of RFL-C40000M-CE continuous fiber laser

The structure size of RFL-C40000M-CE laser is 1145×1700×1445mm (width×height×depth; including casters and rings, without warning light); RFL-C40000M-CE laser weighs less than 1100kg.

The RFL-C30000M/40000M-CE continuous fiber laser uses the RFL-QP output optical cable, and the external dimensions of the output optical cable head are shown in Figure 4.

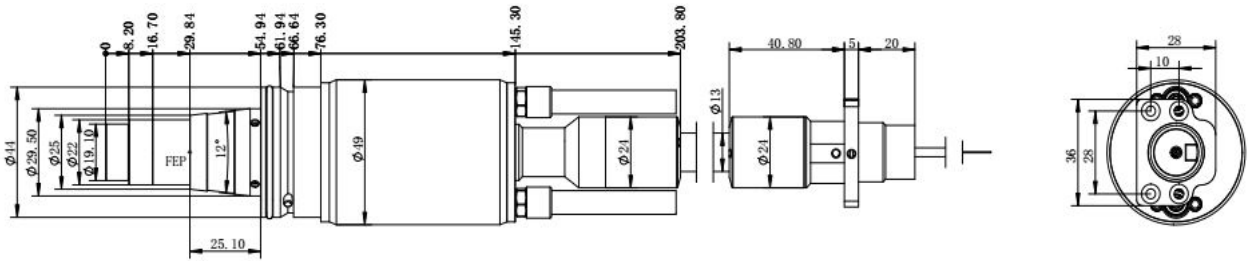

Figure 4 External dimensions of the output optical cable head

Note: The dimensions in the above diagram are in the unit of millimeter (mm).

Before the laser works, make sure that the two copper contacts (Interlock pins) on the output head are shorted, otherwise the laser will not work properly. Before installing the output cable into the processing head, the lens of the output cable must be inspected. If the output cable lens is dirty, the lens must be cleaned. It is forbidden to disassemble the output lens by anyone other than staff in Raycus, otherwise the warranty will be invalidated.

3.2 Installation Rule

- a) Place the laser horizontally in a suitable position and fix it as necessary;
- b) Before the laser is powered on. Please check if the power supply has the correct voltage (380VAC±10%, 50/60Hz, see “Table 2 Product technical data sheet” for details.), whether the grounding line is well grounded;
- c) Connect the power cable and control cable to the product when power supply is OFF;
- d) Connect the cooling system to the laser and output optical cable head according to the water inlet and outlet signs;
- e) Please check the laser output head and make sure to clean it before installing it in the equipment;
- f) Do not step on, squeeze or excessively bend the protective tube during the installation of the output optical cable to avoid damage to the optical fiber;
- g) In the process of installing the optical cable output head, ensure the cleanliness of the surrounding environment (do not use electric fans to dissipate heat when it is hot in summer to avoid large dust in the air);
- h) The minimum bending diameter of the laser transmission cable in non-working conditions such as transportation and storage shall not be less than 40cm. When the laser is emitting light, the minimum bending diameter shall not be less than 60cm;
- i) Customers can use the four lifting rings at the top of the product or the four casters at the bottom to lift or move the product. Before lifting the laser source, make sure that the four lifting rings are installed firmly and reliably. When lifting the laser source, be sure to use the four

lifting rings; when pushing the laser source, please make sure that the support block at the bottom of the horizontal adjustment caster is off the ground. After the laser source is positioned, adjust the support block to make it contact the ground to avoid displacement of the laser source. As shown in Figure 5.

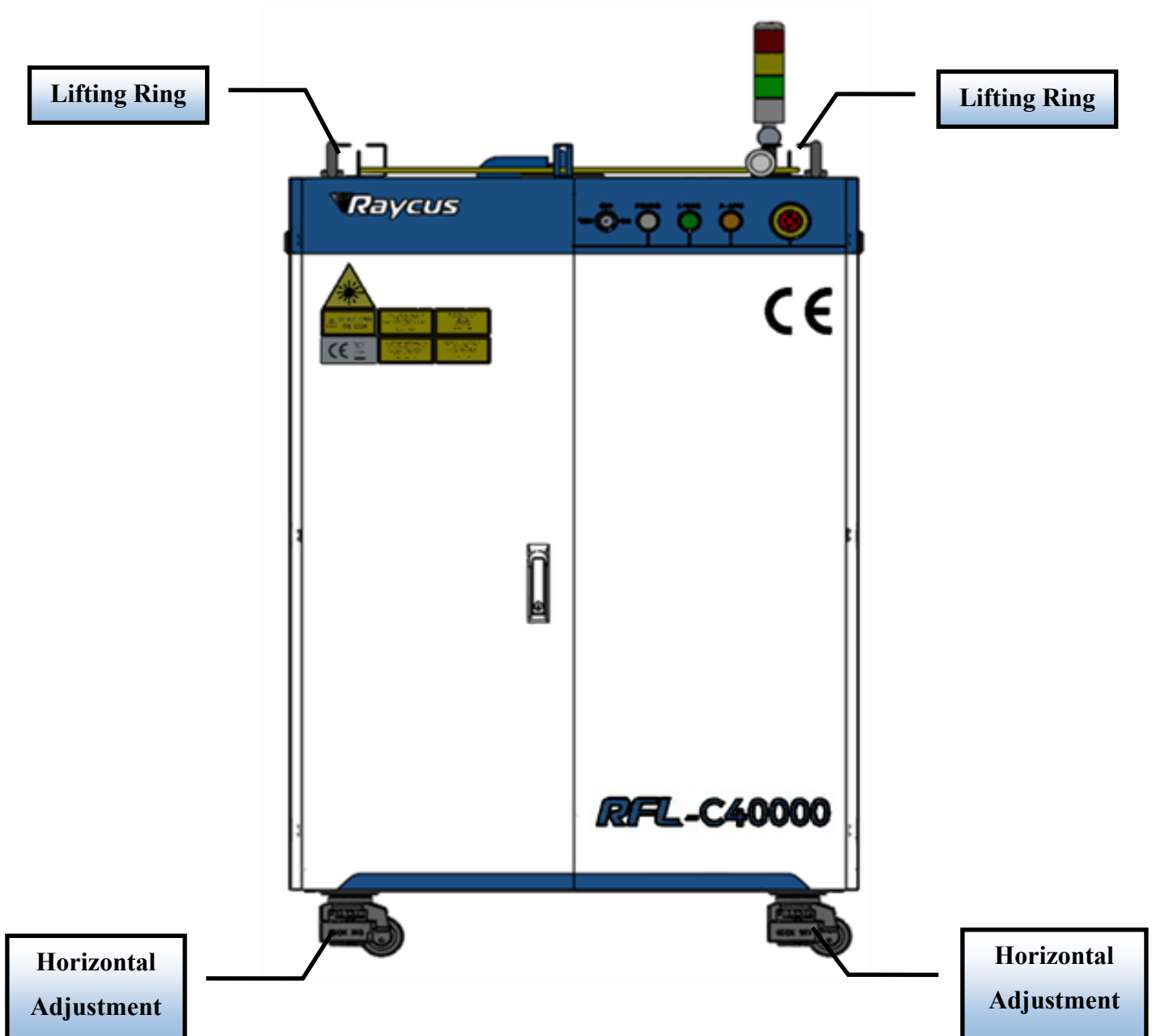



Figure 5 Laser lifting ring and horizontal adjustment caster



CAUTION: All the cables can only be connected when power supply is off. Hot plug may damage the device.

	<p>CAUTION:</p> <p>(1) The placement of the laser output cable should be as natural as possible, and the output cable should not be twisted;</p> <p>(2) If the coil diameter of the output optical cable is too small, it will damage the laser.</p>
	<p>CAUTION:</p> <p>(1) In the process of installation and disassembly, please handle the laser output head gently, and avoid vibration;</p> <p>(2) Before assembling the laser output head, ensure that the optical lens and cutting head cavity are clean and free of pollution.</p>

3.3 Protective End Cap of Output Cable and Using Description

3.3.1 Types of Protective End Caps and Factory Status

For multi-module high-power fiber lasers, the output cable type used is QP output optical cable. There are two types of protective end caps in the machine, as shown in the Figure 6.

Type A end cap: It is assembled on the output optical cable when it leaves the factory. The end cap is equipped with a protective window to ensure the cleanliness of the end cap (or crystal) during transportation.

Type B end cap: It is attached to the packaging accessories and is generally packed in a lamination box. The end cap is not equipped with a protective window, which is used to prevent the end cap from being damaged when the optical cable is loaded with the cutting head (or welding head).

Table 3 Instructions for the use of protective end caps for output optical cables

Type	Optical cable type	Factory end cap type	Use end cap type
RFL-C40000M-CE	QP	Type A end cap (with protective windows)	Type B end cap (without protective window)
RFL-C30000M-CE	QP	Type A end cap (with protective windows)	Type B end cap (without protective window)

Note: According to the difference of the protective end cap of the cable in the actual use of the customer, some models need to replace the protective end cap. Please refer to the " Cleaning Instructions for the Output Optical Cable Before Installation " to clean the output optical cable and the protective end cap.

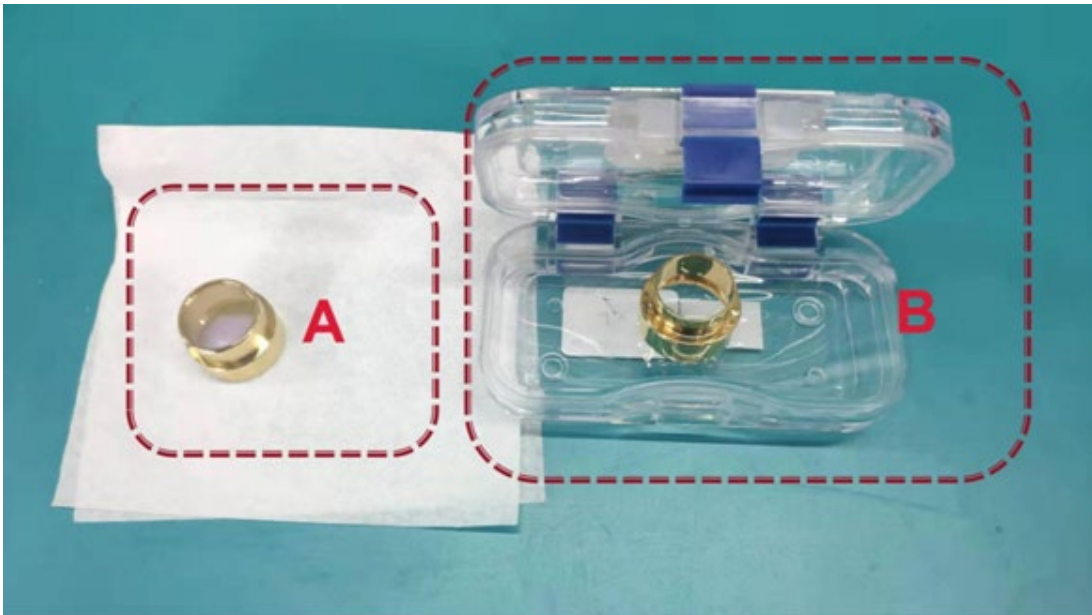

Figure6 Schematic diagram of the protective end cap of the optical cable

3.3.2 Pre-installation Cleaning Instructions for Output Cables

A) Preparation tools

Cleaning agent: absolute ethanol, or isopropyl alcohol.

Cleaning tools: cleaning cotton swabs, dust-free paper, compressed air bottles, etc.

B) Steps

a) Clean workbench should be turned on for at least 5 minutes, and the output optical cable should be taken out of the black packaging box, as Figure 7. The outer surface of the shell shall be blown with compressed air bottle for preliminary cleaning.

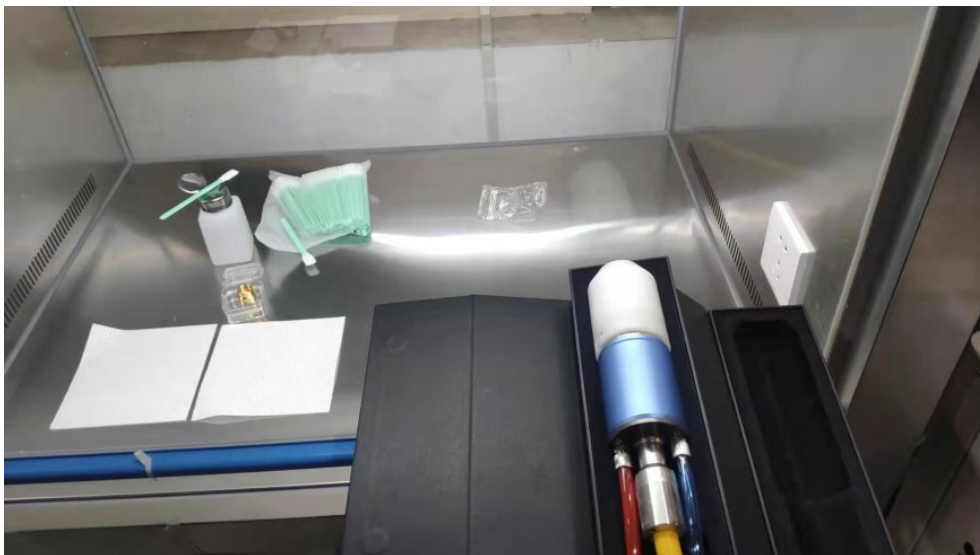

Figure 7 Output cable placed in the box

b) Place the output optical cable in a clean workbench;

Note: The following operations need to be carried out in a clean workbench. If the operation is not carried out in a clean environment, it will cause great risk to the output optical cable; operators need to wear finger cots to operate.



Figure 8 The output optical cable placed in the clean bench with the ventilation turned on

c) Remove the white dust cap and place it face down on new lint-free paper.

Note: The dust-free paper is for one-time use, and there is a risk of dust falling if it is used multiple times.

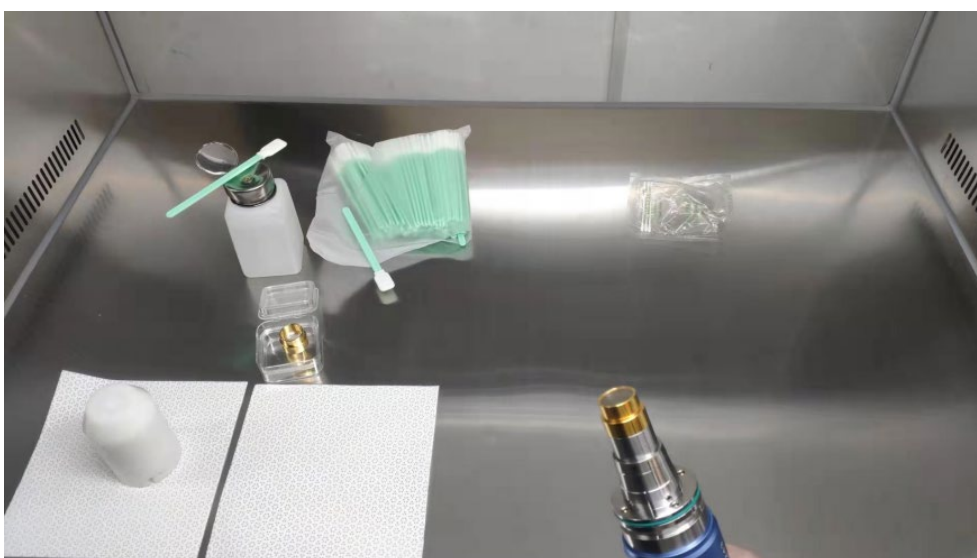

Figure 9 Output optical cable with white dust cover removed

d) Use a cotton swab and anhydrous ethanol to clean the metal casing of the optical cable, then remove the end cap (with protective window) attached to the optical cable, and place it on a clean paper.



Figure 10 Remove the A -type end cap on the optical cable

e) Check the cleanliness of the end caps in this state. If the cleanliness is not enough, please clean the end caps.

Please refer to the cleaning method: <http://www.raycuslaser.com/view/1852.html>

Reference video: <https://mp.weixin.qq.com/s/hRXrPkb8DAyvDYegSWwYLg>.

Note: The end cap cleaning is generally performed by our professional staff. If the customer needs to operate it by himself, we need to go through the relevant training of our staff and obtain the relevant qualifications before the above operations can be carried out. If the operation method is improper, it will cause irreversible and serious damage to the output optical cable during use.

After ensuring the cleanliness, install the B- type end cap. During the installation process, there will be resistance when screwed to the bottom, which is a normal phenomenon. It is necessary to ensure that there is no gap between the end cap and the main body sleeve. And then check the finish and cleanliness of the end cap's glossy surface, as Figure 9 shown. Then connect the fiber optic cable output head to the cutting head (or welding head) with the B- type end cap installed. This operation needs to ensure the cleanliness of the inner and outer surfaces of the cutting head (or welding head) connector.

Note: The connection with the cutting head (or welding head) still needs to be carried out in a clean workbench, and it is necessary to check the cleanliness and smoothness of the relevant components of the cutting head (or welding head) itself.

Keep the corresponding accessories as Figure 11 shown in order to facilitate the re-transportation of the laser or output cable.

Note: The fiber optic cable must be loaded with Type A end caps each time it is transported. That is, every time the output optical cable is unloaded from the cutting head and needs to be

transported, the end cap of type B must be replaced with the end cap of type A , and the white dust cover must be covered, and finally put into a black box for transport.



Figure 11 Accessories that customers need to keep: black protective box, white dust cover, type A end cover

3.4 Cooling Requirements

Table 4 Cooling requirements

Type	Cooling capacity (kW)	Minimum flow (L/min)		Input pressure (Bar)	Hose inner diameter (mm)	Cooling water temperature (°C)
RFL-C30000M-CE	≥60	>290		4~6	Φ32	22±1
		TOP	BOTTOM			
		>110	>110			
RFL-C40000M-CE	≥80	>290		4~6	Φ38	22±1
		TOP	BOTTOM			
		>125	>165			

Requirements on cooling water:

- The laser source cooling water connection is shown in Figure 12, and the arrow direction indicates the water flow direction;
- Cooling water needs to use pure water;
- In order to prevent the water in the water cooler from growing mold and causing pipeline blockage, it is recommended to add alcohol when filling pure water, and the amount of alcohol added is 10% of pure water;

- d) If ambient temperature is between -10°C and 0°C , must be used to use 30% alcohol (volume ratio), and replace it every 2 months;
- e) If ambient temperature is below -10°C , the chiller with both heating and cooling functions must be used, and keep it in full-time operation;

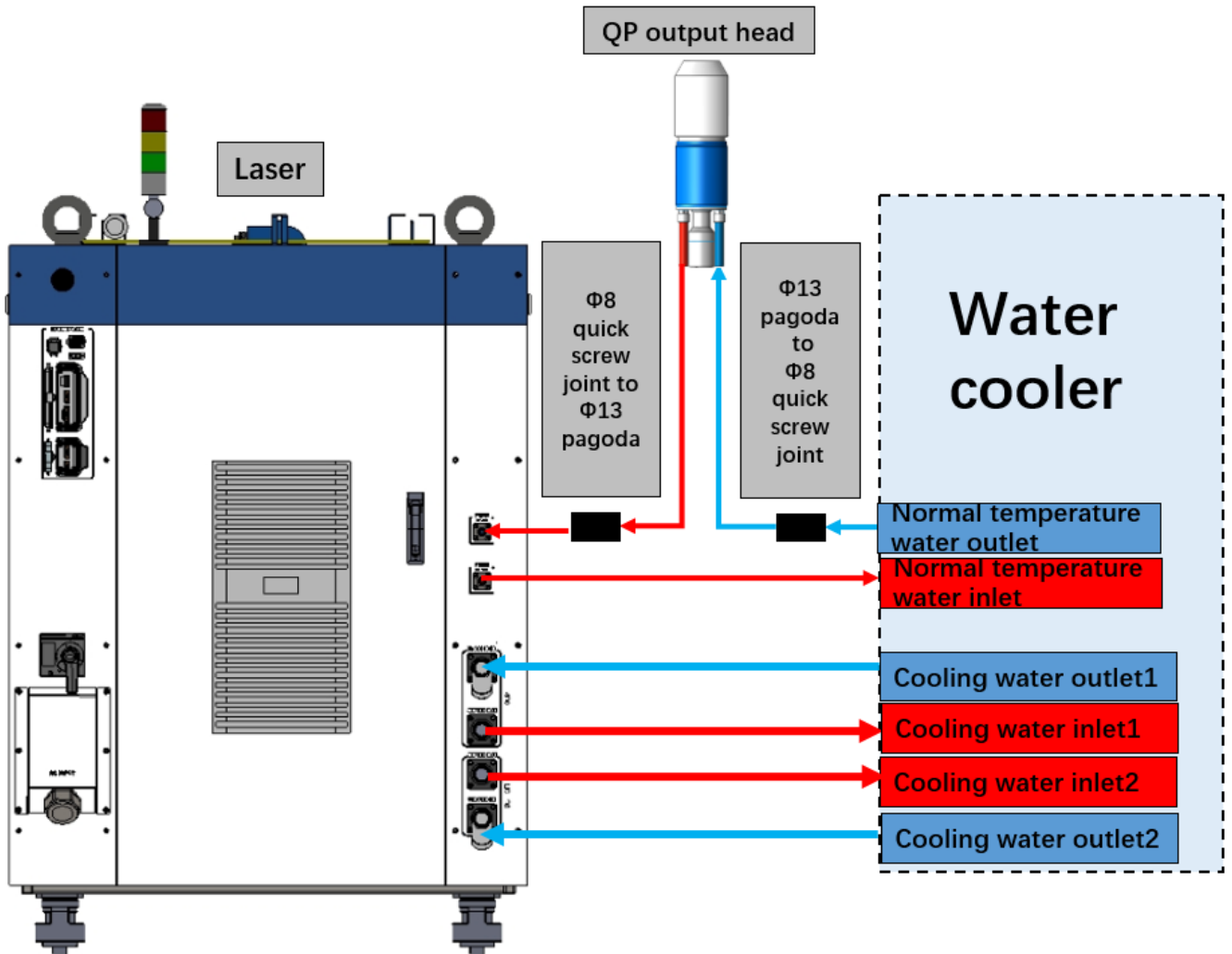

Figure 12 diagram of laser cooling system connection

Water cooling requirements for output optical cables:

- a) Water flow requirements: QP output cable water flow is between 3.0L/min and 4.0L/min;
- b) Water cooling pressure: 0.4Mpa~0.6Mpa at the water inlet;
- c) Water inlet and outlet connector type: M6 to $\phi 8$ quick-tightening connector (QP);
- d) Water pipe type: outer diameter $\phi 8$ and inner diameter $\phi 5.5$ (QP);
- e) Cooling water direction: unidirectional. The water pipe shall be connected in strict accordance with the water inlet and outlet direction marked on the shell.
- f) Cooling water quality: deionized water, distilled water, purified water; it is recommend to replace once a month, and the replacement period should not exceed two months.
- g) PH value of cooling water: 5 ~8;

- h) The water cooler needs to be equipped with a filter element whose filter particle size is less than 100um; the filter element needs to be cleaned once a month.
- i) Maximum cooling water temperature: 35°C;
- j) The lowest cooling water temperature: 5°C greater than the saturated dew point temperature;
- k) Additives in cooling water: meet the above PH value and solid particle size requirements;
- l) Armored pipe bending radius: In non-working conditions such as transportation and storage, the minimum bending radius shall not be less than 20cm. When the laser is emitting, the minimum bending radius shall not be less than 30cm;
- m) Long-term vibration, less than 2G; impact, less than 10G.

Other requirements:

- a) When starting the cooling system for the first time, check the entire water system and joint for water leakage.
- b) If the laser is not used for a long time, the cooling water inside the cooling system and the laser inside should be drained, otherwise the laser equipment will be damaged.
- c) Please use compressed gas below 0.5MPa when emptying water from the device. Failure to do so may cause permanent equipment damage to cooling system.

	<p>CAUTION:</p> <p>(1) Set the water temperature of the cooling system correctly according to the ambient temperature. Setting the water temperature too high will result in the laser not working properly. Setting the water temperature too low will cause condensation inside the laser or the laser output head, which will cause damage to the laser;</p> <p>(2) Before turning on the laser, the cooling system must be working properly and the water temperature should be suitable for the temperature.</p>
---	--

4 Using the Product



Please log in to the official website of Raycus to download the new PC software and the PC software user manual. Website: <http://www.raycuslaser.com>

4.1 Front Panel

Figure 13 shows the front panel.

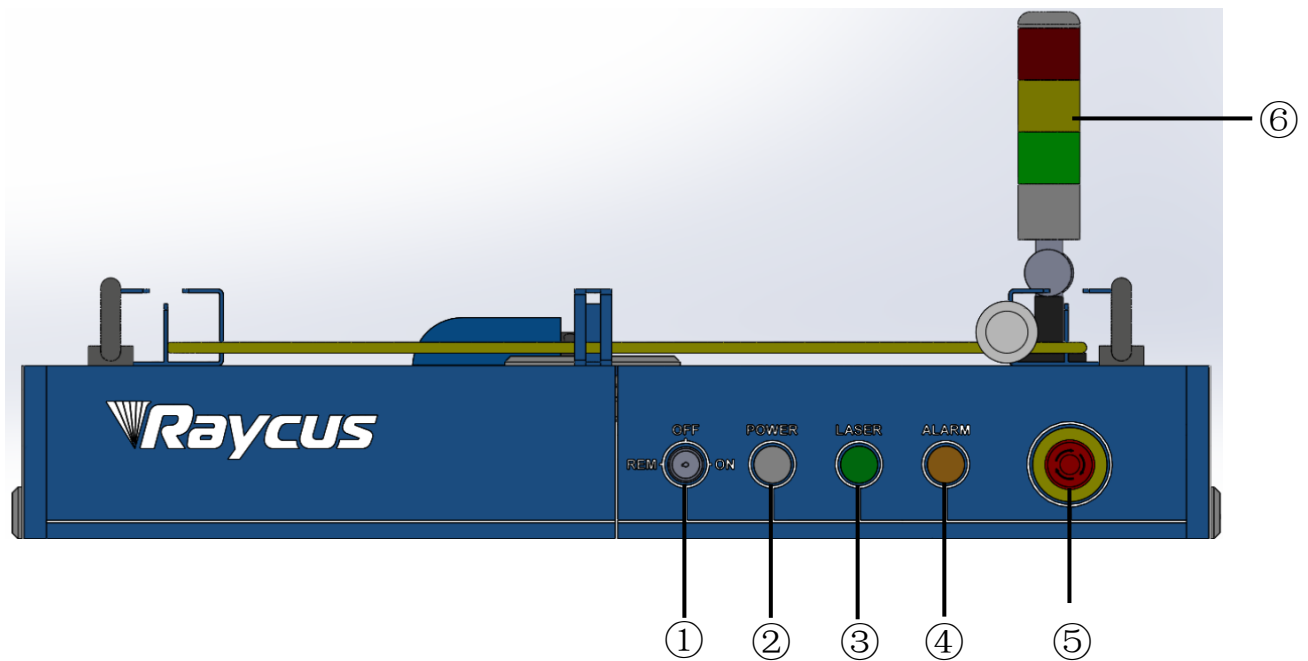

Figure 13 Front view of the panel

Note: ①-REM/OFF/ON ②-POWER ③-LASER

④-ALARM ⑤-STOP ⑥-INDICATOR LIGHT

REM/OFF/ON: The key switch, the main control switch of the laser. Insert the key and turn it to the "ON" position, the main control part of the laser is powered on, and the POWER light is on; Rotate to the "REM" position, you need to close the 8 and 9 pins of the XP2 interface on the rear panel to realize remote power-on, and rotate to REM to activate the hard-wired control mode of the laser.

POWER: Control power indicator, when the white indicator light is on, it means the main control system is on.

LASER: The power button of the laser main power supply has a green light indicator function. After the laser main control system is powered on and all INTERLOCKS are detected as normal, press this button, the laser main power supply is powered on, and the button lights up after the main power supply is powered on.

ALARM: INTERLCOK alarm indication, the ALARM indicator lights up during the power-on self-check on the control panel. After the self-inspection is completed, all INTERLOCK interfaces are normally closed, and the ALARM indicator is off. During the operation of the laser, if any INTERLOCK is disconnected and the laser preparation is not completed, the indicator light will be on.

STOP: Emergency stop button, press to turn off the main power of the laser immediately; turn the button clockwise to release the button, and press the LASER button again to start the main power of the laser.

INDICATOR LIGHT: After the main power supply of the laser is powered on, the green indicator light is on when the laser is Ready; when the laser is emitting light, the red indicator light is on; when the laser has a fault, the yellow indicator light is on, accompanied by an alarm sound.

4.2 Rear Panel

Figure 14 shows the rear panel.

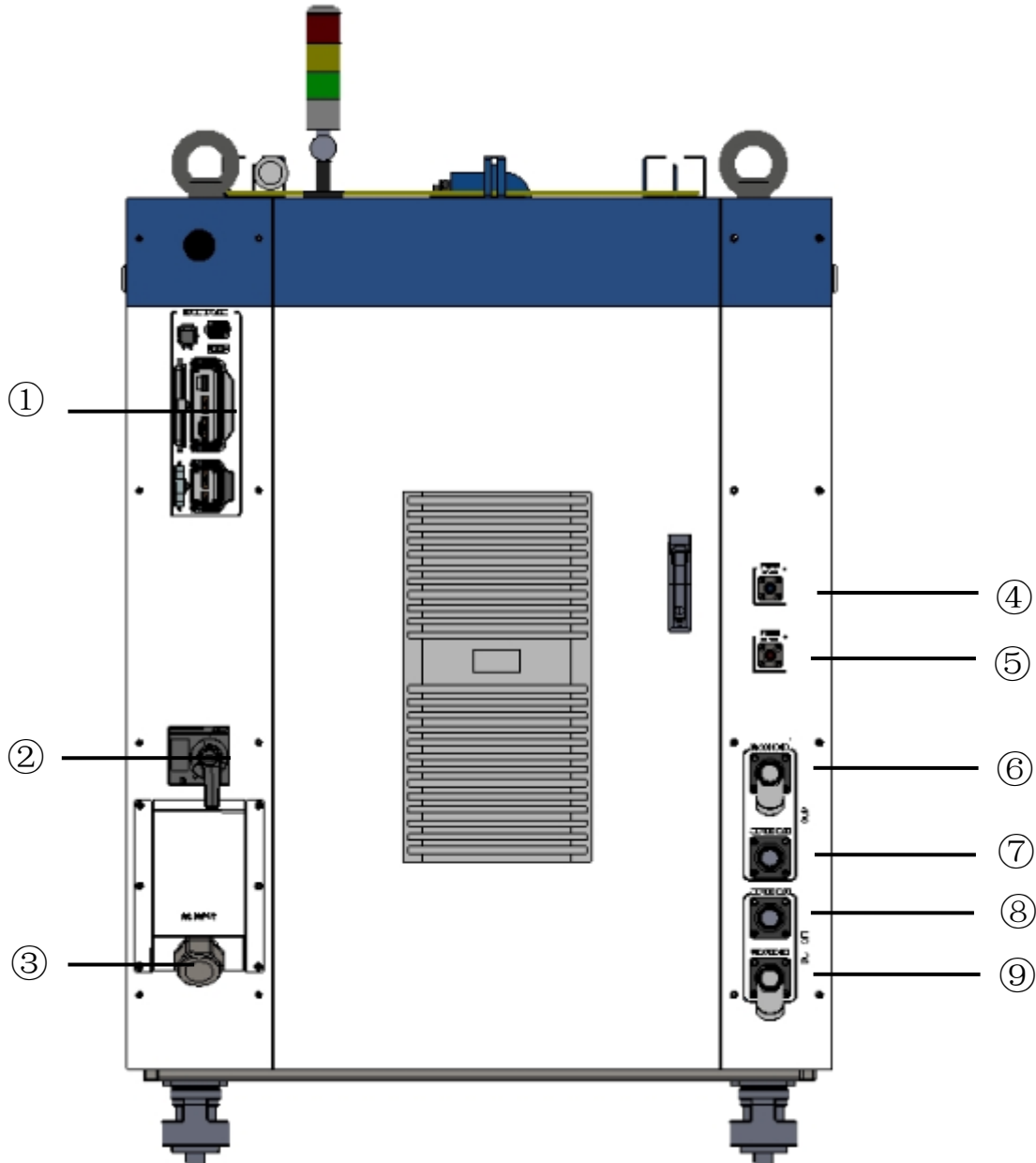

Figure 14 Rear view of product panel

Note: ①- INTERFACE ②-BREAKER ③-AC INPUT

④-FIBER WATER IN ⑤-FIBER WATER OUT ⑥- TOP WATER IN

⑦-TOP WATER OUT ⑧-BOTTOM WATER OUT ⑨BOTTOM WATER IN

①-**INTERFACE:** This interface provides all control signals, including: RS232 communication, laser on/off control, laser remote control mode selection, analog control, modulation signal, Interlock interface, etc. This socket comes with a protective cover and a lock. When you are not using the product, you can cover the power input socket with the protective cover and lock it with the lock.

②-**BREAKER:** The circuit breaker (air switch) on the rear panel of the laser is the main power switch of the laser.

③-**AC INPUT:** The power input socket must be matched with the plug provided by us. This socket comes with a protective cover and a lock. When you are not using the product, you can cover the power input socket with the protective cover and lock it with the lock.

④-**FIBER WATER IN:** Output optical cable water inlet interface, this interface is connected to the water outlet of the normal temperature water of the water cooler, and connected to the $\phi 13$ inner diameter water pipe.

⑤-**FIBER WATER OUT:** Output optical cable water outlet, this interface is connected to the output optical cable water inlet, connected to the $\phi 13$ inner diameter water pipe.

⑥- **TOP WATER IN:** The water outlet of the laser, this interface is connected to the cooling water return port of the water chiller, and connected to the $\phi 32$ inner diameter water pipe.

⑦-**TOP WATER OUT:** The water inlet of the laser, this interface is connected to the water outlet of the cooling water of the water chiller, and connected to the $\phi 32$ inner diameter water pipe.

⑧-**BOTTOM WATER OUT:** The water inlet of the laser, this interface is connected to the water outlet of the cooling water of the water chiller, and connected to the $\phi 32$ inner diameter water pipe.

⑨-**BOTTOM WATER IN:** The water inlet of the laser, this interface is connected to the water outlet of the cooling water of the water chiller, and connected to the $\phi 32$ inner diameter water pipe.

4.3 Power Connection

	<p>CAUTION:</p> <p>(1) Before connecting to the AC power supply, please check whether the supplied AC power supply meets the requirements in Table 1;</p> <p>(2) Incorrect wiring will cause damage to the laser, so please check whether the power cord is connected correctly before powering on the laser.</p>
---	--

The power cable provided by the company should be directly connected to the AC INPUT interface on the rear panel of the laser.

The definition and parameter requirements of AC INPUT line interface are shown in Table 5

Table 1 The definition and parameter requirements of AC INPUT line

RFL-C30000M/40000M-CE Definition and parameter requirements of laser AC input line

Interface definition	Identification	Wire diameter		Color
		30000M	40000M	
AC380V-L1	L1	35mm ²	50mm ²	Brown
AC380V-L2	L2	35mm ²	50mm ²	Black
AC380V-L3	L3	35mm ²	50mm ²	Gray
Safety Ground	PE	35mm ²	50mm ²	Kelly Green

The standard length of power cord provided by the company is 15m.

4.4 Control Interface Definition

This type of laser does not provide a control signal line, except a control signal connector. The appearance of the joint is shown in Figure 15.

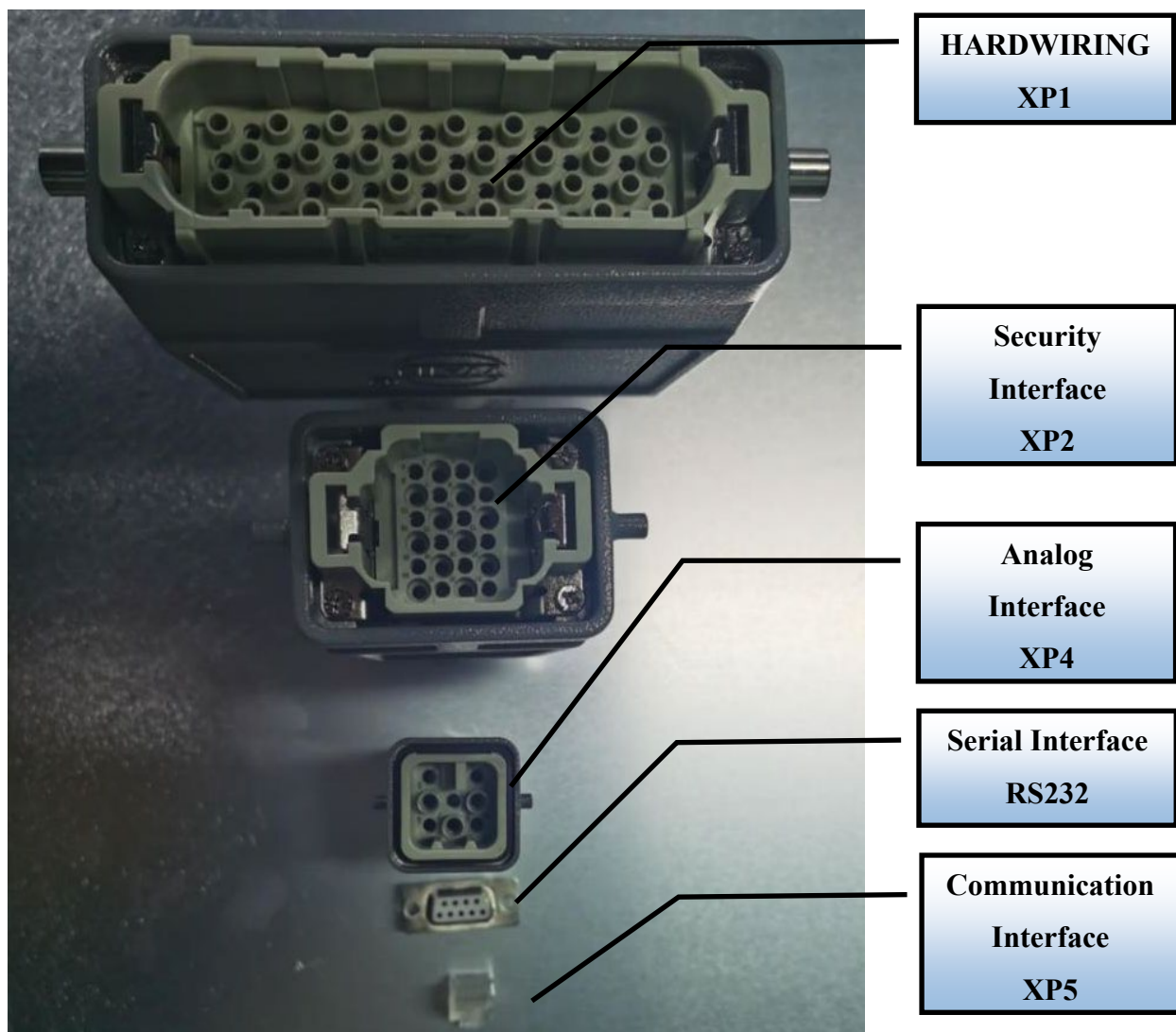

Figure 15 Control signal line

4.4.1 Safety XP2 Interface

24-pin safety interface, with remote control system power-on, remote main power power-on and active and passive output of some lasers. The detailed interface definition is shown in Table 6.

Table 6 XP2 security interface definition

Pin No.	Type	Description
1	MOD+	Output control, voltage input signal; laser ON: 18V~30V; laser OFF: -3V~2V;
2	MOD-	Maximum modulation frequency: 5kHz;.
3	OUT(FET S pole)	Laser output indication, MOS pipe D, S output;
4	OUT(FET D pole)	current<0.5A, V_{DS} <30V, passive signal.
5	OUT	Connect the negative pole of the external laser-emitting indicator, current<100mA
6	OUT	Connect the negative pole of the external power-on indicator, current<100mA
7	OUT(24V)	Connect the positive pole of the external laser-emitting indicator; active signal, current<400mA
8	IN	On REM mode, the main control board is powered on when pin-8 and pin-9 are closed; 24V active contact output, no external voltage or grounding.
9	IN	
10	24V OUT	Connect the positive pole of the external power-on indicator; active signal, current<400mA
11	OUT	Emergency output 1 on the front panel, relay output contact, passive contact, current <100mA, voltage<30V;
14	OUT	If the current panel stop pressed, pin-11 and pin-14 are open, or else close.
12	OUT	Emergency output 2 on the front panel, relay output contact, passive contact, current <100mA, voltage<30V;
13	OUT	If the current panel stop pressed, pin-12 and pin-13are open, or else close.
15	OUT(FET S pole)	Main power supply power on output indication, MOS pipe D, S output
16	OUT(FET D pole)	current<0.5A, V_{DS} <30V, passive signal.
17	IN	Interlock1 input, the pin-17 and pin-20 should be closed normally; active contacts, no external voltage or grounding.
20	IN	
18	IN	Interlock2 input, the pin-18 and pin-19 should be closed normally; active contacts, no external voltage or grounding.
19	IN	
21	IN	Close the pin-21 and pin-22 to start the main power supply remotely. (The function is the same as the LASER button on the front panel.) active contacts, no external voltage or grounding.
22	IN	
23	OUT	Pin-23 and pin-24 indicate the laser key switch status: Opened - the laser key switch is in the OFF position;

24	OUT	Closed - The laser key switch is in the ON or REM position. Passive contact, external voltage signal, the voltage is less than 30V, and the
----	-----	--

4.4.2 HARDWIRING XP1

64 pin hardwire interface, control signal input and output interface of laser in remote mode. Input high level is greater than 18V valid, input low level is less than 3V valid. Specific interface definitions are shown in Table 7 below.

Table 7 XP1 hardwire interface definition

	Interface Definition		Type	Description
	Pin No.	Pin Definition		
XP1	A1	Laser request signal	Input signal	Laser request signal, only after this bit is valid will the laser receive other XP1 hard-wired interface input commands.
	A2	Programming mode start-up execution	Input signal	When A8~A14 are all low, A2 is the laser enable signal; if there is a high level in A8~A14, it enters the programming mode, the program command is executed from the rising edge of A2, and the program number is determined by A8~A14. Users need to ensure that A2 is always high during program execution (B9 is high), and then set A2 low after the program is executed (B9 is low). The laser output power is set by the program if the program number is not 0000000; the laser output power is set by AD analog if the program number is 0000000 and the A6 is high.
	A3	Enabling Internal patter	Input signal	High level enables PC software control function.
	A4	Reset signal	Input signal	Active on rising edge; to clear laser alarm bit; effective high-level time at least 1 ms.
	A5	Red light indicator	Input signal	The guide led light indicator is on when A5 is high.
	A6	Simulation control enabling energy	Input signal	When A6 is high, the analog input signal is enabled. The program number Program Number is required to be set to 0, or A8~A14 are all low (non-programming mode).

XP1	A7	Stop programming Mode	Input signal	In programming mode, program execution is terminated immediately when A7 is high.
	A8~A14	Set program Number	Input signal	Hardwired address for selecting a stored program number. A8 is the lowest bit and A14 is the highest bit.
	A15	synchronous input	Input signal	Synchronous input signal, used with the program command WAIT in programming mode.
	A16	COM	Reference ground	Reference ground for all input signals of XP1.
	C1	Laser-driven power supply	Input signal	The rising edge turns on the main power, and the falling edge turns off the main power.
	C2	Not connect		
	C3~C6	Select the optical gate channel	Input signal	C3 is the lowest bit, C6 is the highest bit: 0000-close all optical gate channels; 0001-open channel 1; 0010-open channel 2; 0011-open channel 3. (For lasers with optical gate channels only, these pins are spare in other lasers)
	C7	Enable QCW mode	Input signal	Enable QCW mode (For lasers with QCW modes only)
	C8~C16	Not connect		
	B1	The laser is ready	Output signal	The laser is ready to emit laser light when B1 is high.
	B2	Laser output	Output signal	The laser is emitting light when B2 is high.
	B3	The laser operates in internal mode	Output signal	The laser works in the internal control mode when B3 is high. In this mode, the laser can be controlled by communication.
	B4	Laser anomalies	Output signal	The laser is abnormal when B4 is high.
	B5	Laser red light indication	Output signal	The laser is emitting guide light when B5 is high.
	B6	AD mode	Output signal	The laser works in the AD mode when B6 is high.
	B7	Feedback signal of A1	Output signal	The laser has received the A1 signal when B7 is high.
	B8	Main power supply of laser	Output signal	The main power of laser is on when B8 is high.
	B9	Program running	Output signal	Laser program is running when B9 is high.
	B10	Program ending	Output signal	Laser program is ended when B10 is high. B10 clears when the A2 is invalid.

B11	Abnormal Wave Mode Termination	Output signal	Laser program is ended abnormally when B11 is high. B11 can be cleared when the A4 is high.
B12	Synchronous output	Output signal	Sync signal output in programming mode.
B13	Warning output	Output signal	Laser is warning when B13 is high.
B14	Not connect		
B15	External power supply (Positive pole)	Input signal	The 24 V input voltage, power supply of all XP1 output signal. Only when B15 and B16 access 24 V power, output signal is effective.
B16	External power (Negative pole)	Input signal	
D1~D4	Current optical gate channel	Output signal	Indicates the current optical gate channel: 0000-all optical gate channels closed; 0001-channel1 opened; 0010-channel 2 opened; 0011-channel 3 opened. D1 is the lowest bit, D4 is the highest bit.
D5	Water cooler warning	Output signal	Indicates the current water temperature warning, indicating a risk of emitting laser. (Used with Water Cooler)
D6	Water cooler alarm	Output signal	Indicates the current water temperature alarm, prohibits laser emission. (Used with Water Cooler)
D7	QCW mode	Output signal	Output signal indicating that the current laser operates in QCW mode (For lasers with QCW mode only)
D8~D11	Laser hardwire address	Output signal	Set the laser hardwire address (Coding-Cable function): 0000- laser 0; 0001- laser1.
D12~D16	Not connect		

4.4.3 Serial RS232 Interface

The 9-pin serial interface RS232 is used for the communication between the laser and the upper computer. It can be used to communicate with the PC software of Raycus or the software of the upper computer which integrates the communication protocol of Raycus. The definition is as follows.

Table 8 RS232 serial interface definition

Pin No.	Type	Description
2	IN	RXD, serial receiving pin of laser
3	OUT	TXD, serial transmitting pin of laser
5	COM	GND, signal ground

4.4.4 Analog Interface XP4

The analog interface, an 8-core Harting interface, is used to control the output power of the laser by analog in AD mode, and can also monitor the output light and power feedback signals of the laser. The interface definition is shown in Table 9 below.

Table 9 XP4 analog interface definition

Pin No.	Type	Description
1	IN	0V~10 V analog signal, laser power control signal in AD mode , 0V~10 V corresponding to 0%~100% output power
2	AGND	Analog signal ground
3	OUT	Power amplifier voltage output. 0 V: 0% laser power output; 8 V: 100% laser power output.
4	Reference	Reference ground for power amplifier voltage
5	OUT	High back-amplification voltage (reserve, no use)
6	Reference	Reference ground for high backup voltage (reserve, no use)

4.4.5 ETHERNET Interface XP5

Table 10 XP5 communication interface definition

Pin No.	Function	Description
1	TX+	Data transmission+
2	TX-	Data transmission-
3	RX+	Data acceptance+
4	N/C	Not connect
5	N/C	Not connect
6	RX-	Data acceptance-
7	N/C	Not connect
8	N/C	Not connect

4.5 Introduction to Safety Interlock

Raycus' product is designed with a safe interlocking loop, which is a two-channel system with output monitoring and manual reset. When the safety interlocking circuit is open, the safety circuit will disconnect the working power of the optical module, that is, the main power supply of the optical module. To start the main power supply, you must close the two interlocking channels (24 pin interface: short 17 and 20, short 18 and 19). Otherwise, the main power will be turned off and the laser can not be turned on at this time. When one of the channels is open, the laser main power supply is impossible to start until the

other channel is open, and then the two channels are closed before the laser main power supply can be started.

If the interlock is closed (the stop button is also released) and there is no error alarm, press the start (LASER) button to start the main power supply, and “the main power has been started” pin of the external interface(XP1-B8) will have a high-level output. When the security interlocking circuit is open or the error is detected, the main power supply of the optical module will be turned off, and the B8 of XP1 interface will become low level. The detected “error state” is latched and the on-board relay opens the manual reset loop with monitoring until the error is cleared, thus preventing the laser from being restarted. If errors such as short circuit between interlocking channels or short circuit of start (LASER) button are detected, the safety loop can not be reset before the error is cleared.

4.6 Start Operation Sequence

- a) Turn on the water cooler, check whether the water pipe is leaking, turn off the water cooler and connect electrically.
- b) Make sure the circuit breaker is in a OFF state and the stop button on the front panel of the laser EMERGENCY STOP pressed; all electrical connections must be completed before the laser is powered on.
- c) Confirm that the three-phase electrical connection is correct and the power supply meets the specifications of the power supply.
- d) Close the rear panel circuit breaker, release the laser front panel emergency stop switch; turn on the key switch, and the laser has a temperature and humidity alarm, turn off the key switch. After the air conditioner works for 10 minutes, turn on the key switch again. Wait for the air conditioner to continue working for 10 minutes until the temperature and humidity alarm of the laser does not appear, at this time, turn off the key switch and turn on the water cooler; ensure that all laser doors are closed, optical cable output head has been inserted into the cutting head (or corresponding equipment), all interlock interfaces have been closed;
- e) Select the required control mode according to “5. Control Mode Selection”, turn on the key switch, start the main power supply waiting for the laser to Ready, the laser Ready, the tricolor green light above the machine, representing that the laser can emit light.

5 Control Mode Selection

The Raycus high-power CW laser has two control modes: namely ON mode and REM mode. Users can select the mode to be entered through the key on the front panel.

Table 11 Function of ON and REM mode

ON	AD	External	programming	Power	Laser ON and OFF	Red laser
----	----	----------	-------------	-------	------------------	-----------

Mode	Mode	control	mode			
	close①	close②	-	communication (13)	communication (11)	communication (12)
	Enable ③	close②	-	XP4-1/2 pin pressure	communication (11)	communication (12)
	close①	Enable④	-	communication (13)	XP2-1/2 pin level	communication (12)
	Enable ③	Enable④	-	XP4-1/2 pin pressure	XP2-1/2 pin level	communication (12)
REM Mode	close⑤	close⑥	close⑦	communication (13)	communication (11)	communication (12)
	Enable ⑧	close⑥	close⑦	XP4-1/2 pin pressure	communication (11)	XP1-A1/A5 is high level
	close⑤	Enable⑨	close⑦	communication (13)	XP1-A1 laser request is high XP1-A2 laser emission enable is high XP2-1/2 input MOD singal	XP1-A1/A5 is high level
	Enable ⑧	Enable⑨	close⑦	XP4-1/2 pin pressure	XP1-A1 laser request is high XP1-A2 laser emission enable is high XP2-1/2 input MOD signal	XP1-A1/A5 is high level
	close⑤	Enable⑨	Enable⑩	determined by programming command	XP1-A1 laser request is high XP1-A2 high level indicates operating program	XP1-A1/A5 is high level

- ① Send "DEC" by communication, or click button of Analog Control on the PC software;
- ② Send "DLE" by communication, or click button of External Control on the PC software;
- ③ Send "EEC" by communication, or click button of Analog Control on the PC software;
- ④ Send "ELE" by communication, or click button of External Control on the PC software;
- ⑤ XP1-A1 is high level, XP1-A6 is low level or suspending;
- ⑥ XP1-A1 is high level, XP1-A3 is high level;
- ⑦ XP1-A1 is high level, XP1-A8~A14 is all low level or suspending;
- ⑧ XP1-A1 is high level, XP1-A6 is high level;
- ⑨ XP1-A1 is high level, XP1-A3 is low level or suspending;
- ⑩ XP1-A1 is high level, XP1-A8~A14 is not all low level;
- ⑪ Emit laser: Send "EMON" by communication, or click button of Emission "ON" on the PC software;
- ⑫ Turn off the laser: Send "EMOFF" by communication, or click button of Emission "OFF" on the PC software;

- ⑬ Emit red light: Send "ABN" by communication, or click button Guide laser "ON" on the PC software;
- ⑭ Turn off red light: Send "ABF" by communication, or click button of Guide laser "OFF" on the PC software;
- ⑮ The communication sends "SDC XX" to set the power percentage, XX represents the power percentage, or click button Power\Duty cycle\Frequency\Pulse width and then click the button of Set on the PC software.

5.1 ON Mode

In the On mode, the user can send commands to set different working mode through PC software or direct communication. After the laser is powered on again, the mode before power failure will be memorized.**AD Enable Mode**

When AD mode is enabled, the laser power is determined by the analog voltage of pin 1 and pin 2 of XP4. If the AD mode is not enabled, the laser power can be set through the PC software or send the "SDC XX" command.

5.3 Emission External Control Enable

When the emission external control is enabled, the laser emission is determined by the level difference between the pins of MOD+ and MOD- in the XP2 port; if the emission external control is not enabled, the laser emission or shutdown are determined by the emit button on the PC software. Also, you can send "EMON" command to turn laser emission on, and send "EMOFF" command to turn laser emission off.

5.4 Guide Laser (Red Guide Beam) Control

In "ON" mode guide laser can only be turned on/off by using PC software, or by sending command of "ABN" (on) / "ABF" (off).

The red light module inside the laser works through communication, so there is a time delay of at least 10ms for the opening and closing of red light;

When the red light is on, the laser cannot be set to "Ready". Only after the red light is turned off the laser can be set to "Ready". (This limit can be changed, please contact Raycus Engineer).

5.5 Programming Mode

In "ON" mode, when the current program number of the laser is not 0, the laser runs in the "Programming" mode. Please use the Raycus PC software to edit the waveform and select the pre-run program number.

When the laser is in the internal control mode:

Send the “EMON” command or press the button of Emission “ON” button, the laser will start to run the program,

Send the “EMOFF” command or press the button of Emission “OFF” button can terminate the laser emission at any time;

When the laser is in the external control mode, the rising edge of MOD starts to operate the program, and the falling edge of MOD can terminate the program at any time.

5.6 REM Mode

5.6.1 AD Enable Mode

When both A1 and A6 of XP1 are set high, A8~A14 are set low, the laser operates in AD mode, and the current laser power is determined by the analog voltage of pin 1 and pin 2 of XP4; When A6 of XP1 is set low or suspended, the current laser power is set by sending "SDC XX" command through PC software or communication.

5.6.2 Emission External Control

When both A1 and A3 of XP1 are set high, the laser is in the internal control mode, and the laser emission is controlled by the “light on button” by PC software or through communication sending "EMON" to emit light, and "EMOFF" to control the light off; When A1 of XP1 is set high, A3 is suspended or set low, the laser is in the external control mode, the output light is determined by the TTL level of the MOD signals(pin1 and pin2 of XP2) and A2 of XP1.

5.6.3 Red Light Control

When both A1 and A3 of XP1 are set high, the laser is in the red light internal control mode, and the red light is controlled by the PC software red light button or through communication by sending "ABN" or "ABF" command to control the ON/OFF of the red light; When A1 of XP1 is set high, and A3 is suspended or set low, the laser is in external control mode, and the red light is controlled by A5 of XP1.

The red-light module in the laser works by means of communication, so there is a time delay of at least 10ms when the red light is turned on and off.

When the red light is on, the laser cannot be set to Ready. Only after the red light is turned off the laser can be set to “Ready”. (This limit can be changed, please contact Raycus Engineer).

5.6.4 Programming Mode

When A1 of XP1 is set high and A8-A14 is not 0, the laser is in “Programming Mode”. At this time, the laser emission is controlled by A2 of XP1, and the laser emission waveform is determined by the edited waveform.

6 Laser Wiring Diagram and Operation Steps

6.1 Internal Control in ON Mode

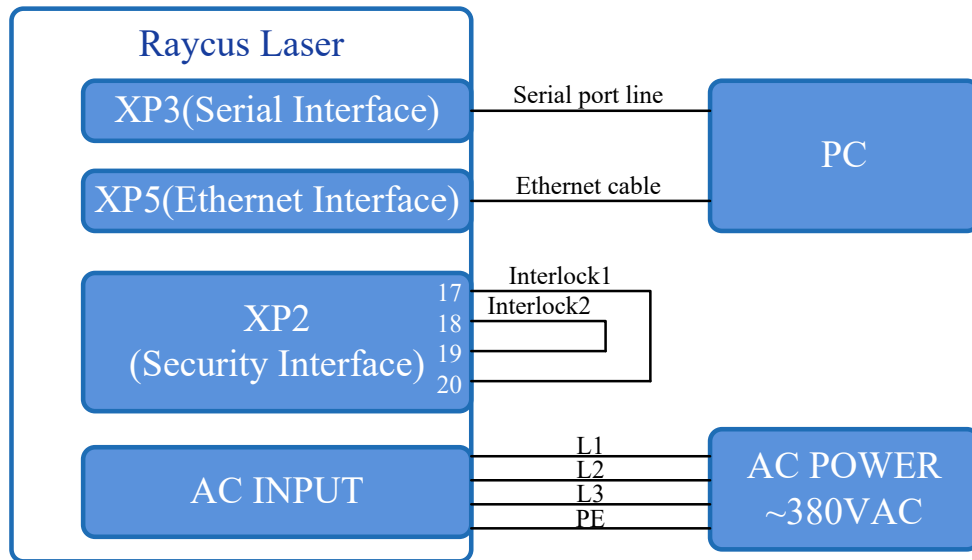

Figure 16 Software mode wiring diagram when key switch at “ON” position

Operations Steps

- a) Turn the knob switch on the rear panel to “ON”
- b) Turn the key switch to “ON”
- c) Open the Raycus PC software
- d) Click the guide laser “ON” button to view the guide laser
- e) Turn off “AD” mode and turn off external control mode (this mode can be memorized when power off)
- f) Click the main power “ON”
- g) Waiting for “Ready”
- h) Set laser emission parameters
- i) Click the laser “ON”.

6.2 Laser Operating in External Control Mode

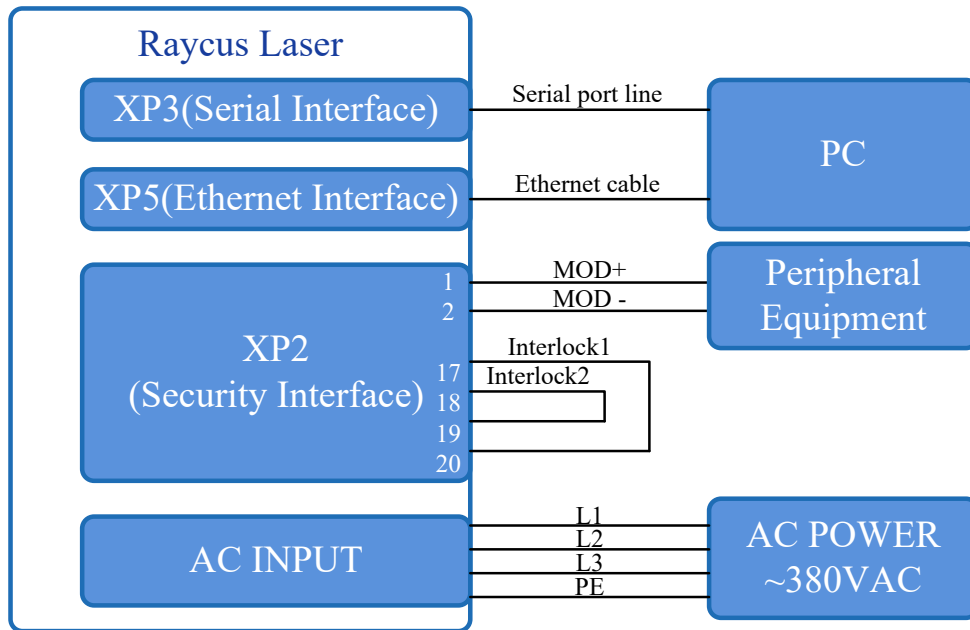

Figure 17 The wiring diagram of laser operating in external control mode

Operations Steps

- Turn the knob switch on the rear panel to "ON"
- Turn the key switch to "ON"
- Open the Raycus PC software
- Click the guide laser "ON" button to view the guide laser
- Turn off "AD" mode and turn on "External Control" mode (this mode can be memorized after
- power off)
- Click the main power "ON"
- Waiting for "Ready"
- Set the percentage of laser emission power
- Turn on the laser through the high level output by MOD signal

6.3 In ON Mode, the Laser Emission Power is Externally Controlled by Analog Signal

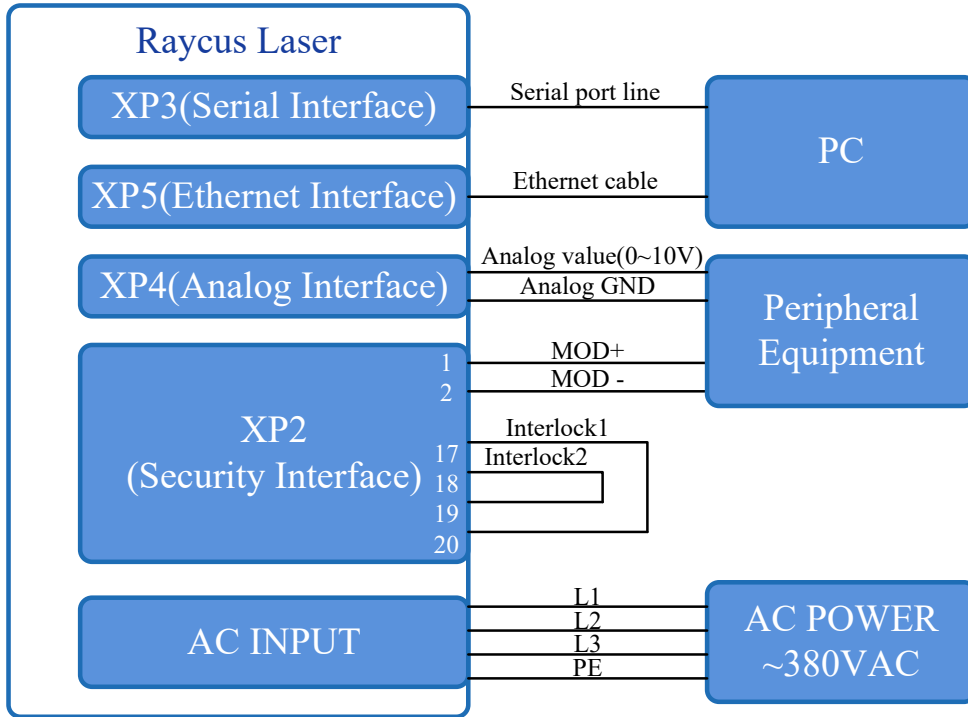

Figure 18 In ON mode, the wiring diagram of the power and laser emission controlled by analog signal

Operations Steps

- a) Turn the knob switch on the rear panel to “ON”
- b) Turn the key switch to “ON”
- c) Open the Raycus PC software
- d) Click the guide laser “ON” button to view the guide laser
- e) Turn on the “AD” mode and turn on “External Control” mode (this mode can be memorized after power off)
- f) Click the main power “ON”
- g) Waiting for “Ready”
- h) The control board card outputs power analog and emit control signal.

6.4 Laser Operating in External Control Programming Mode

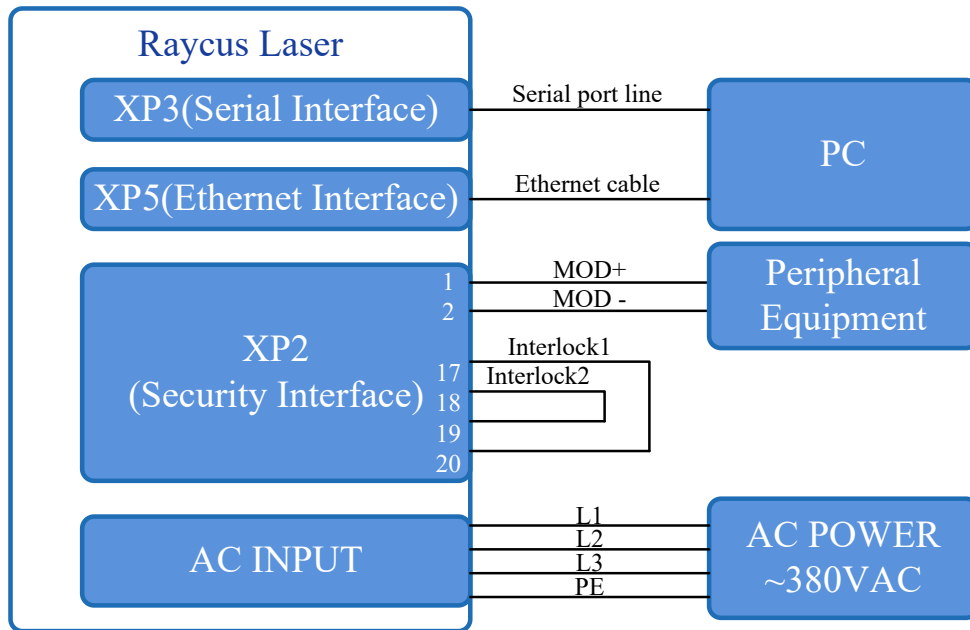

Figure 19 Wiring diagram of external control laser emission in programming mode, in ON mode

Operations Steps

- Turn the knob switch on the rear panel to “ON”
- Turn the key switch to “ON”
- Open the Raycus PC software
- Click the guide laser “ON” button to view the guide laser
- Click the main power “ON”
- Waiting for “Ready”
- Set the pre-executed waveform number (the program number is greater than 0)
- Start waveform at the rising edge of MOD signal.

NOTE:

The high-level time of MOD must be greater than the program running time. If MOD gives a falling edge in advance, the Raycus PC software will display that the laser program is abnormally terminated.

6.5 Set the Power Analog Quantity in REM Mode to Control the Laser Emission

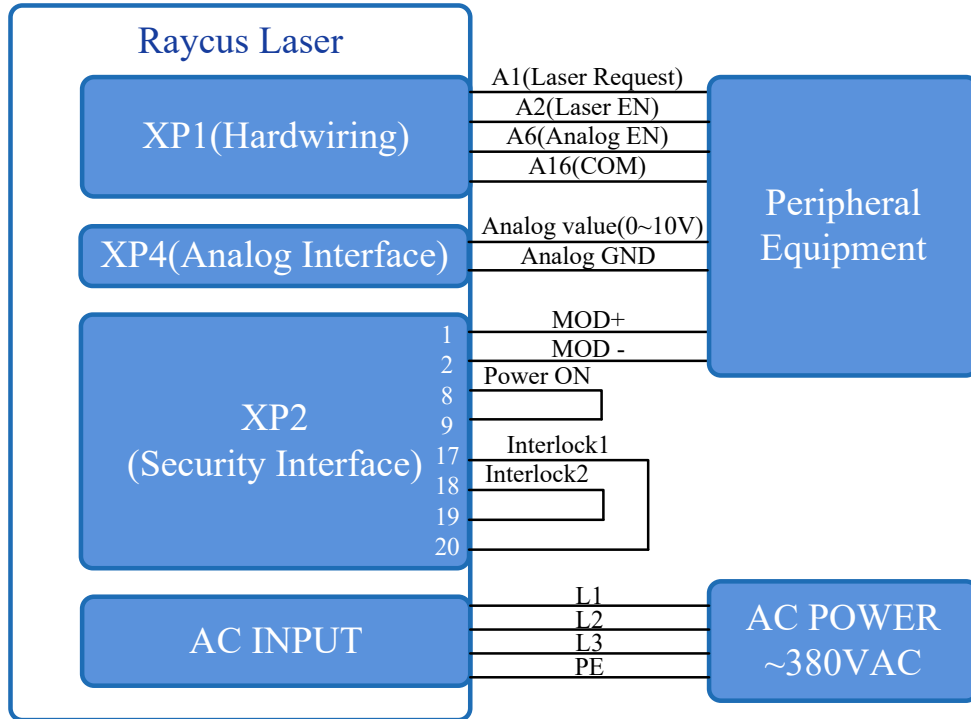

Figure 20 REM mode power and laser emission are externally controlled wiring diagram

Operations Steps

- a) Turn the knob switch on the rear panel to “ON”
- b) Turn the key switch to “REM”
- c) Short-circuit pin 8/9 on XP2
- d) XP1-A1 connects to 24V, XP1-A6 connects to 24V
- e) Connect XP1-A5 to 24V and turn on the guide laser; after checking the optics, connect XP1-A5 to 0V and turn off the guide laser
- f) XP1-C1 is connected to 24V, and the main power is turned on (operator can also directly press the LASER button, or clicks the main power “ON” on the Raycus PC software)
- g) Waiting for “Ready”
- h) XP1-A2 connects to 24V, and the control board outputs analog and MOD signals

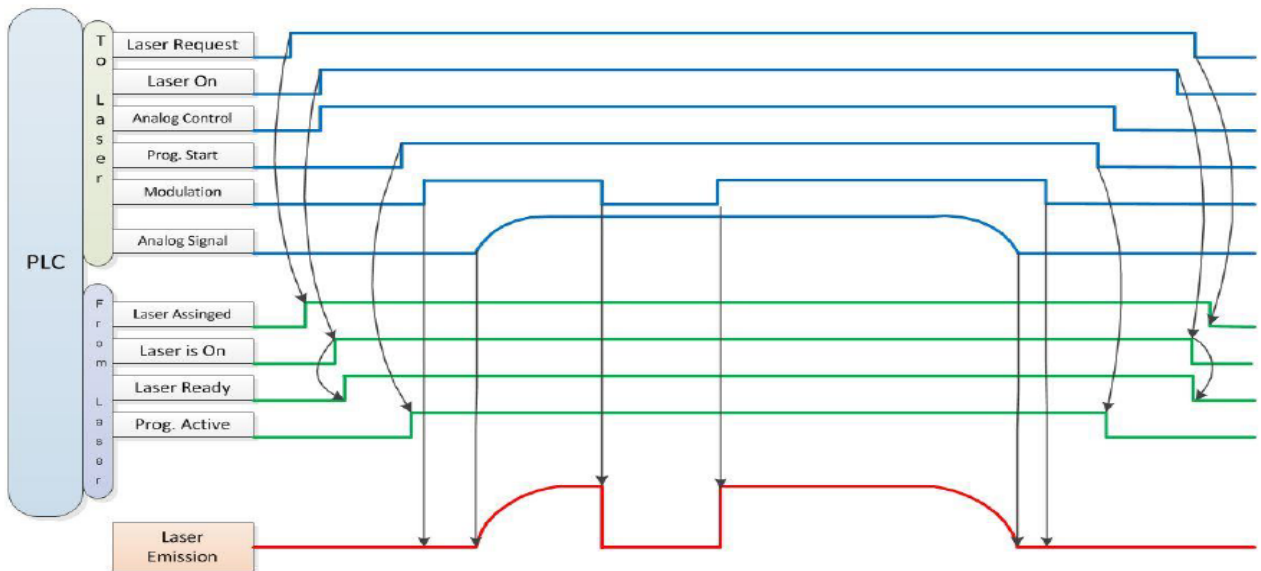

Figure 21 Timing diagram

6.6 Power Communication Setting in REM

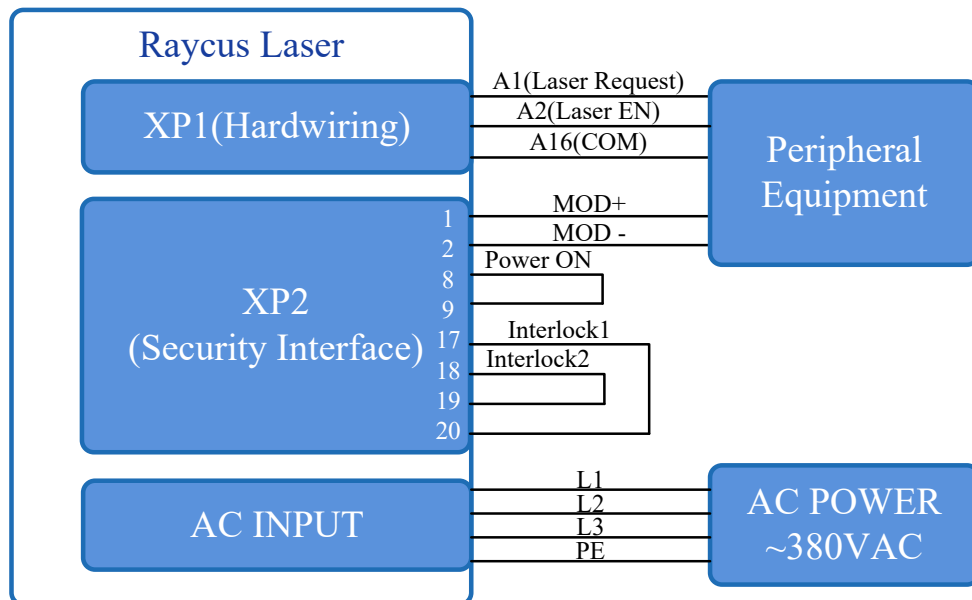

Figure 22 Wiring diagram of power internal control and laser emission external

Operations Steps:

- Turn the knob switch on the rear panel to "ON"
- Turn the key switch to "REM"
- Short-circuit pin 8/9 on XP2
- XP1-A1 connects to 24V
- Connect XP1-A5 to 24V and turn on the guide laser; after checking the optics, connect XP1-A5 to 0V and turn off the guide laser

- f) XP1-C1 is connected to 24V, and the main power is turned on (users can also directly press the “LASER” button, or clicks the main power “ON” on the Raycus PC software)
- g) Waiting for “Ready”
- h) The Raycus PC software sets the power, XP1-A2 is connected to 24V, and the control board card outputs MOD signal

6.7 Programming Mode in REM Mode

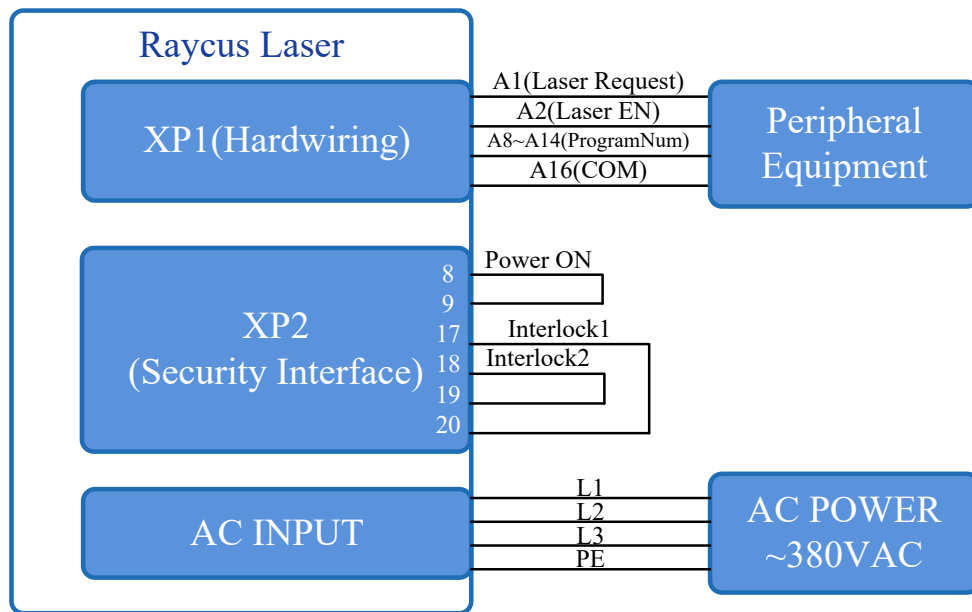

Figure 23 Wiring diagram of programming mode in REM Mode

Operations Steps:

- a) Turn the knob switch on the rear panel to “ON”
- b) Turn the key switch to “REM”
- c) Short-circuit pin 8/9 on XP2
- d) XP1-A1 connects to 24V
- e) Connect XP1-A5 to 24V and turn on the guide laser; after checking the optics, connect XP1-A5 to 0V and turn off the guide laser
- f) XP1-C1 is connected to 24V, and the main power is turned on (users can also directly press the “LASER” button, or clicks the main power “ON” on the Raycus PC software)
- g) Waiting for “Ready”
- h) XP1-(A8-14) select the number of the pre-executed program, set XP1-A2 high to start executing the program.

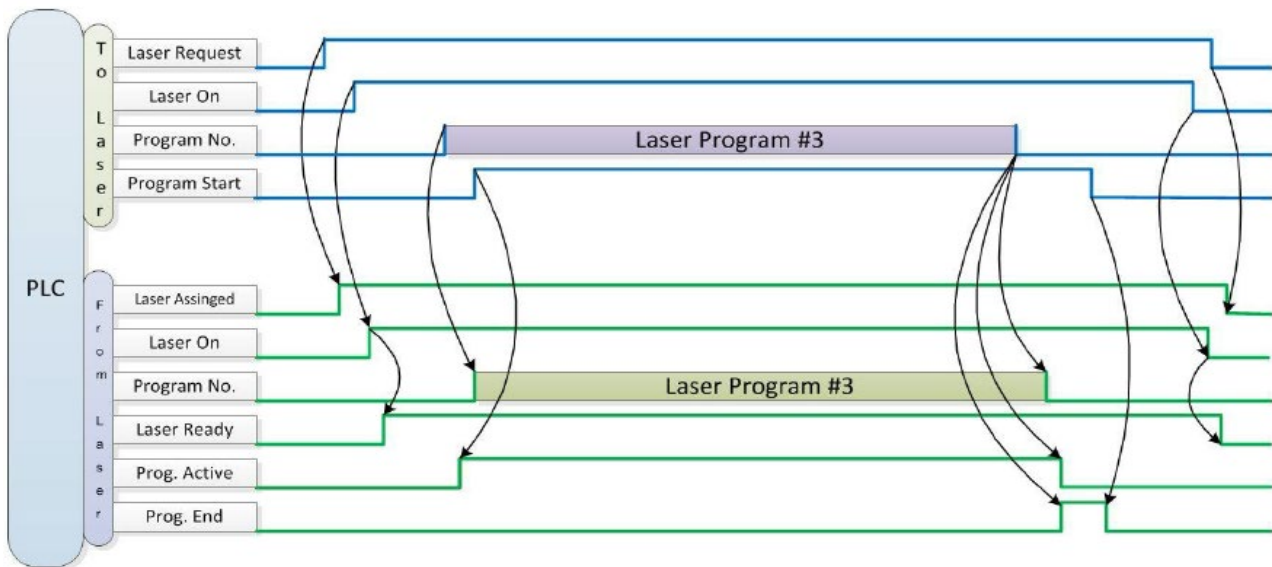

Figure 24 Timing diagram

7 RS232 and ETHERNET Communication Command

7.1 Port Configuration

RS-232 configuration is as follows:

Baud rate :9600, data bit :8, stop bit :1, no parity bit and no control flow.

Ethernet port is configured as follows:

Default laser IP address :192.168.0.10

Laser port :10001

7.2 Laser Communication Protocol (Network Port & Serial Port)

All commands and return values in this Agreement are composed of ASCII characters. Note the following points when entering :

- Commands generally consist of three or four letters, sometimes with additional values.
- All commands and return values end with the enter character (CR,0x0D, \r. If this product receives a string with a 'enter' character but the command is invalid, the Command Err! is returned r".
- For easy identification, all commands are capital letters, but in fact this product is not case-sensitive. To facilitate identification, add a space between the command and the parameter.
- This product sends a return value for each command received. The return value generally contains the command content itself. If the returned content contains a numeric value or contains an error type, the returned command content is separated from the numeric value or from the error type.

The specific agreement content and command examples of this product are shown in Table 12.

Table 12 Specific protocol contents and command examples of laser

Command	Description	Command example
ABF	Aiming Beam OFF –Turn off red	Send: 'ABF\r' Return: 'ABF\r'
ABN	Aiming Beam ON – Turn on red	Send: 'ABN\r' Return: 'ABN\r'
DEABC	Disable External Aiming Beam Control	Send: 'DEABC\r' Return: 'DEABC\r'
EEABC	Enable External Aiming Beam Control	Send: 'EEABC\r' Return: 'EEABC\r'
DEC	Disable External Control	Send: 'DEC\r' Return: 'DEC\r'
EEC	Enable External Control	Send: 'EEC\r' Return: 'EEC\r'
DLE	Disable Hardware Emission Control	Send: 'DLE\r' Return: 'DLE\r'
ELE	Enable Hardware Emission Control	Send: 'ELE\r' Return: 'ELE\r'
EM OFF	Stop Emission	Send: 'EMOFF\r' Return: 'EMOFF\r'
EMON	Start Emission	Send: 'EMON\r' Return: 'EMON\r'
MPWR OFF	Main Power OFF	Send: 'MPWROFF\r' Return: 'MPWROFF\r'
MPWR ON	Main Power ON	Send: 'MPWRON\r' Return: 'MPWRON\r'
SPW	Set Pulse Width	Send: 'SPW 100\r' Return: 'SPW:100\r' (Set pulse width as 100ms) Other return values: 'ERR: input Err\r' (Input pulse width <0.0001) 'ERR: Out of Range\r' (Over maximum pulse width) 'ERR: Duty Cycle too High\r' 'ERR: Duty Cycle too Low\r' 'SPW:100, Duty=100%\r'
SPRR	Set Pulse Repetition Rate	Send: 'SPRR 1000\r' Return: 'SPRR: 1000\r' 'ERR: input Err\r' 'ERR: Out of Range\r' 'ERR: Duty Cycle too High\r' 'ERR: Duty Cycle too Low\r' 'SPW: 100, Duty=100%\r'

SDC	Set Diode Current (%) The set value must be less than 100% and above the minimum current setting value, which can be set to 0. If the set value is greater than 100, the default is input 100.	Send: 'SDC 100\r' Return: 'SDC: 100\r' Other return values: 'ERR: Input Err\r' 'Laser is worked in AD Mode\r'
RCS	Read Current Set point	Send: 'RCS\r' Return: 'RCS: 56.7\r' (The current set value is 56.7 %)
RPRR	Read Pulse Repetition Rate (Hz)	Send: 'RPRR\r' Return: 'RPRR:10\r' (Repeat frequency is10Hz)
RBT	Read Board Temperature	Send: 'RBT\r' Return: 'RBT:36.6\r'
RPW	Read Pulse Width (ms)	Send: 'RPW\r' Return: 'RPW:5.5\r' (pulse width is 5.5ms)
RCT	Read Laser Temperature	Send: 'RCT\r' Return: 'RCT:34.5\r'
PERR	Reset Errors	Send: 'PERR\r' Return: 'PERR\r'
SUT	Set Up Time (ms)	Send: 'SUT 50\r' Return: 'SUT:50\r'
SDT	Set Down Time (ms)	Send: 'SDT 50\r' Return: 'SDT:50\r'
RUT	Read Up Time (ms)	Send: 'RUT \r' Return: 'RUT:50\r'
RDT	Read Down Time(ms)	Send: 'RDT \r' Return: 'RDT:50\r'
PSRT	Program Start	Send: 'PSRT 1\r' Return: 'PSRT:1\r'
PSTP	Program Stop	Send: 'PSTP\r' Return: 'PSTP\r'
ECM	Enable Calibration Mode –Power linear correction mode (in this mode, the external analog is corrected and output after filtering, so the response time of AD analog is larger than that of through mode)	Send: 'ECM \r' Return: 'ECM\r'

DCM	Disable Calibration Mode (AD analog response time is less than 100 us in this mode)	Send: 'DCM\r' Return: 'DCM\r'	
Others	Command Error	Send: 'BGM\r' Return: 'Command Err!\r'	
STA	Read Device Status – Read the product status. A return value of 32-Bit digital information. The meaning of each Bit is as follows (undefined or 'reserved' Bit negligible):	Send: 'STA' Return: 'STA:4100' returned value 4100(Decimal) can be converted to 0 x1004 (hexadecimal), and then converted to binary to see that Bits2 and 12 have been set. The laser enable is on and the modulation mode is enabled.	
	Bit 0		Normal operation
			Authorization time
	Bit 1		Normal
			Temperature too high
	Bit 2		Emission off
			Emission on or in preparation
	Bit 3		No high reflection
			High reflection Abnormal
	Bit 4		External AD mode=off
			External AD mode=on
	Bit 5		Power Correction Mode=off
			Power Correction Mode=on
	Bit 6		Normal
			Sub-controlling communication abnormal
	Bit 7		Normal
			Sub-module abnormal
	Bit 8		Guide red light=off
			Guide red light=on
	Bit 9		The laser is not ready
	The laser is ready		
Bit 10	QCW mode=off		
	QCW mode=on		
Bit 11	Module Main Power=off		
	Module Main Power=on		
Bit 12	Modulation mode=off		
	Modulation mode=on		

Bit 13	Normal
	Leakage sensors 1 leaking
Bit 14	Normal
	Leakage sensors 2 leaking
Bit 15	No laser
	Laser is power on
Bit 16	Gate mode=off
	Gate mode=on
Bit 17	AC input normal
	AC input abnormal
Bit 18	External Emission control=off
	External Emission control=on
Bit 19	Normal
	Laser fault
Bit 20	Slow up slow down mode off
	Slow up slow down mode on
Bit 21	A laser operates in ON" mode
	A laser operates in REM" mode
Bit 22	Wave mode off
	Wave mode on
Bit 23	Surge protector normal
	Serge protector failure
Bit 24	Normal
	Low temperature fault
Bit 25	Normal
	Humidity alarm
Bit 26	Normal
	Water flow meter 1 Flow Alarm
Bit 27	Red light internal control
	Red Light External Control
Bit 28	Normal
	Water flow meter 2 Flow Alarm
Bit 29	Normal
	Module locked

	Bit 30	Optical circuit safety interlock normal	
		Optical circuit safety interlock abnormal	
Bit 31	Normal		
	High average power		

8 The instructions of Raycus software

8.1 The main menu of the Raycus computer software display

The main interface of the Raycus software display is shown in Figure 25.

Basic usage method of Raycus laser Raycus software:

- a) Click "Mode", select "Control Mode", and click "OK" to enter the control mode;
- b) Click "Power on main power OFF" to power on the main power supply of the laser. This button changes to "Power on main power ON", and the "Power" indicator in the main status bar is lit;
- c) Click the red light ON button to turn off the red light and wait for the laser preparation to complete. After the laser preparation is completed, the "Ready" indicator in the main status bar will be lit;
- d) Set "Power [%]" or "Power [W]", set "Frequency" and "Duty Cycle", and click "Set";
- e) Click "Laser Emission ON", the laser emits light, and the "Emission" indicator in the main status bar is lit;
- f) If it is necessary to set the output optical power to a ramp up or ramp down mode, you can set the "Power ramp up time" and "Power ramp down time" in the "Laser" area, and click "Set" to enter the power ramp up or ramp down mode for the laser;
- g) If you need to edit the optical power waveform yourself, you can refer to Section 8.13 of this operating instruction to edit the waveform, set the "Program Number" in the "Laser" area, enter the programming mode, and click "Laser Emission ON" to output the laser according to the edited waveform.

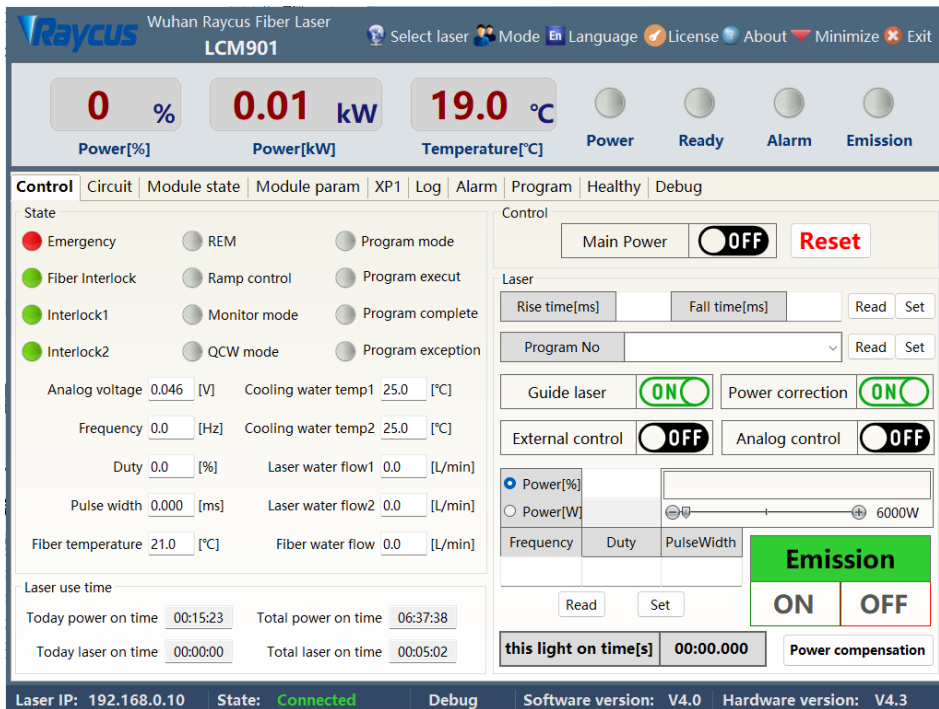

Figure 25 Main menu of Raycus Software Display

8.2 Selecting the laser

Raycus provides Raycus Laser Management.exe software to set the IP address of Raycus lasers, and controls lasers with different IP addresses on the upper computer by selecting the IP address. Click Select Laser on the upper computer toolbar, as shown in Figure 26. After confirming the IP address, you can connect to the laser. After successful connection, see Figure 27. The factory default IP address of Raycus Laser is 192.168.0.10.

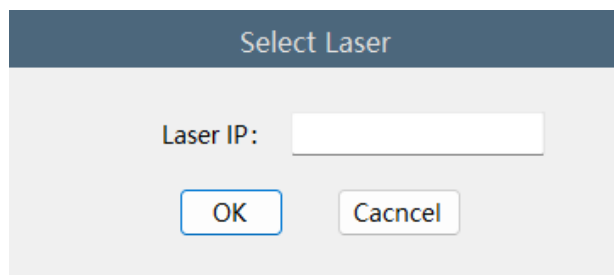

Figure 26 Display menu for multiple laser control areas

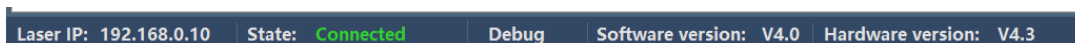

Figure 27 Raycus software and laser communication status display menu

8.3 Selection of Raycus software working mode

The laser operation mode is set through the Raycus software, and its operation menu is shown in Figure 28. The definitions of various modes are shown in Table 12. When the display programming mode is selected, the waveform editing menu will be displayed on the software.

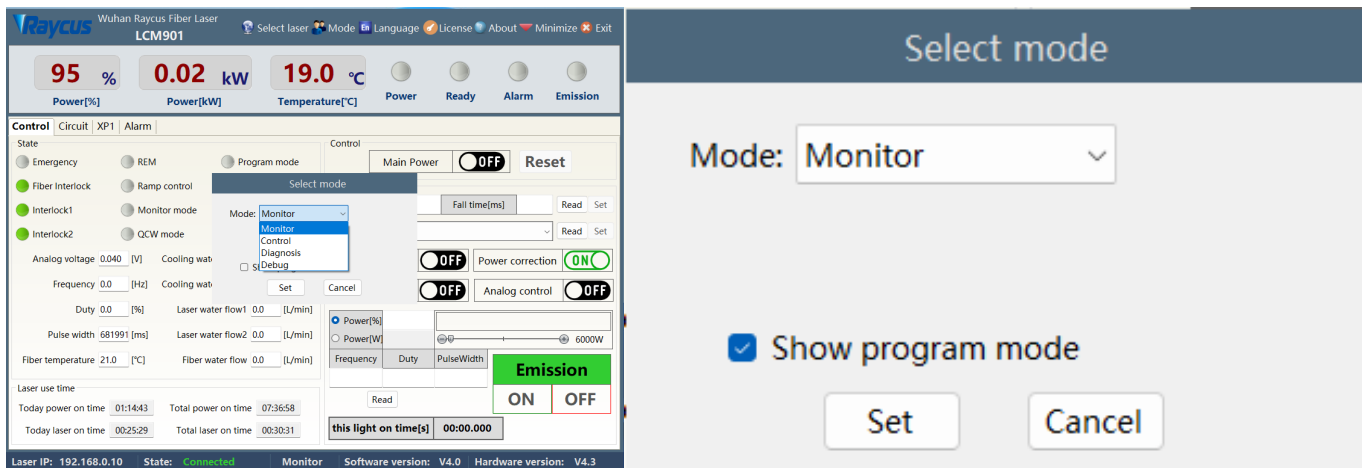

Figure 28 Display menu for laser operation mode selection display area

Table 12 Laser operating modes and their meanings

Mode selection	Meaning of mode selection mode
Observing Mode	This mode provides the most concise software menu
Control Mode	This mode enables the upper computer to control buttons, and users can use this mode to control the laser
Diagnostic Mode	This mode displays all the states and parameters of the laser for easy diagnosis of the
Debug Mode	can modify the parameters of the laser (it is necessary to verify the laser password)

8.4 Language Selection

The laser language selection operation menu is shown in Figure 29. Currently, only Simplified Chinese and English languages are supported. After clicking to set the language, you need to reopen the Raycus software before the settings will take effect.

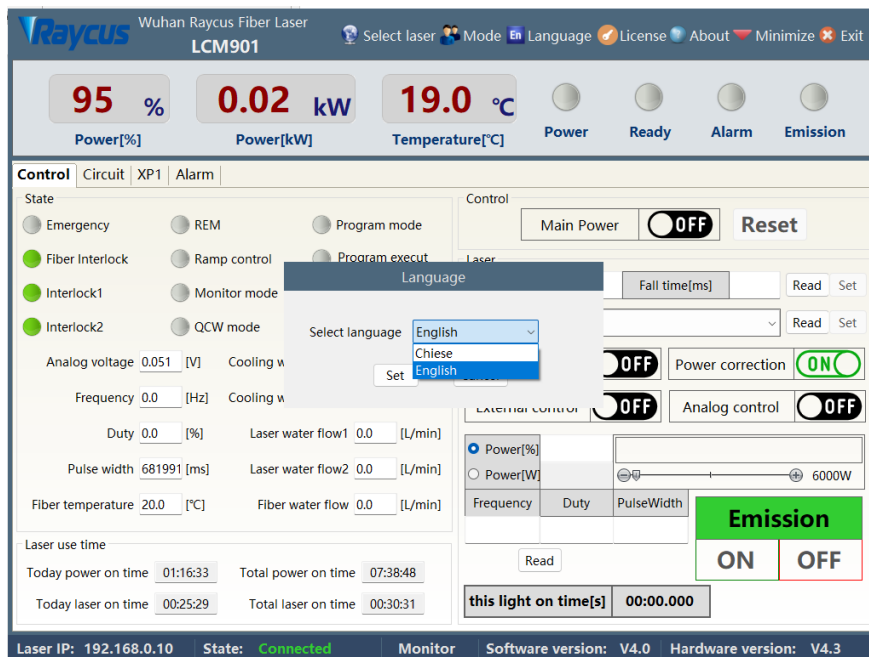

Figure 29 Laser Language Selection Operation menu

8.5 About

Information such as laser factory time, model, laser serial number, master serial number, key version number, and system information can be queried in the "About" item of the Raycus software. The specific display menu is shown in Figure 30.

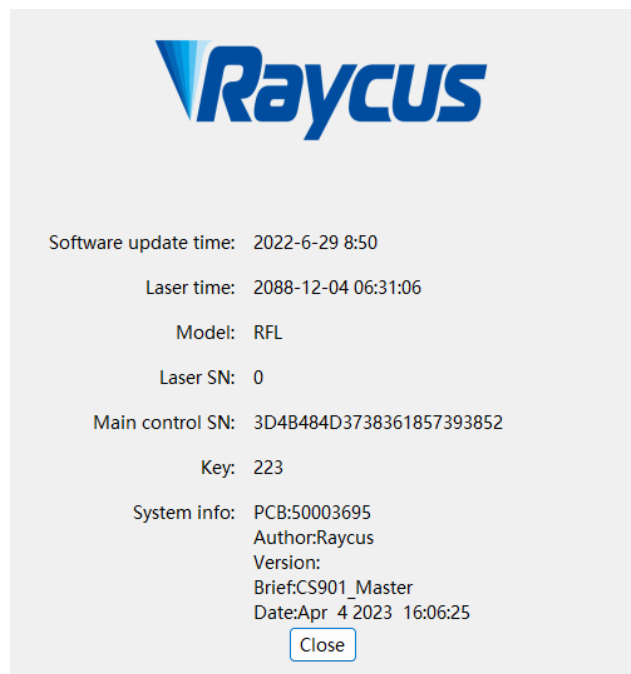

Figure 30 Laser related information query menu

8.6 Main status display area

The main status display area of the laser is shown in Figure 31, and the display content is shown in Table 13.

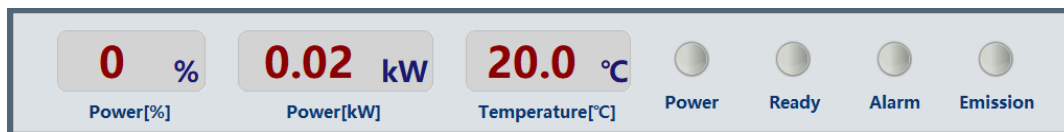

Figure 31 Schematic diagram of the main display area of the laser

Table 13 Display Contents and Meaning of the Main Display Area of the Laser

Display Content	Meaning
Output power [%]	real-time display of the currently set power percentage
Output power [W]	Displays the average output power of the current laser in real-time
Laser temperature(°C) [°C]	Real time display of the current laser water cooled plate temperature
The Power indicator	indicates the current status of the main power supply: green - the main power supply is powered on gray - the main power supply is not powered on
The Ready indicator	indicates the Ready status of the current laser: green - the laser is ready to output laser light; Grey - laser is not ready
The Alarm indicator	indicates the current alarm status of the laser: yellow - the laser is abnormal, Grey - no abnormality in the laser
The Emission indicator	indicates the current output state of the laser: red - the laser is outputting laser light, Grey - laser not outputting laser light

8.6.1 Laser operation status display area

The laser operation status display area is shown in Figure 32, and the display content is shown in Table 14.

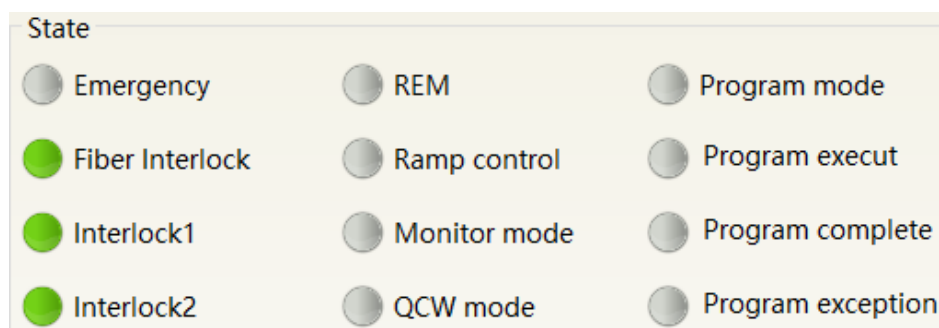

Figure 32 Schematic diagram of laser operation status display area

Table 14 Contents and meanings displayed in the main display area of the laser

Display	Meaning
Emergency stop	red - indicates that the emergency stop button on the front panel of the laser is pressed; Grey - indicates that the emergency stop button on the front panel of the laser has been reset
The status of output optical cable	green - the interlock contact on the output optical cable head is closed; Grey - The Interlock contact on the output cable head is open
InterLock1 closed	green - the 17 and 20 pins on the XP2 safety interface are closed Grey - pins 17 and 20 on the XP2 safety interface are disconnected
InterLock2 closed	green - pins 18 and 19 on the XP2 safety interface are closed Grey - pins 18 and 19 on the XP2 safety interface are disconnected
REM	green - the laser operates in REM mode Grey - laser operates in ON
Power ramp up ramp down mode	green - the laser is operating in power ramp up ramp down mode Grey - the laser is not operating in power ramp up ramp down mode
Monitoring mode	green - The upper computer software is in monitoring mode and can only view laser status information, and cannot perform any control on the laser. This mode is activated when the 10001 port of the laser is used by the customer. Grey - upper computer software running in normal mode
QCW mode	green - the laser is operating in QCW mode Grey - laser operating in continuous mode
Programming mode	green - the laser is running in programming mode, and the program number is not 0; Grey - The laser is not running in programming mode and the program number is 0
Executing	green - the laser is executing a program in programming mode Grey - The laser is not in programming mode or the program in programming mode is not being executed
Execution Complete	Green - Laser execution completes the program in programming mode Grey - The laser is not in programming mode or the program has not been
Execution abnormal	red - The laser is in programming mode and the execution program is abnormally interrupted Grey - The laser is not in programming mode or the laser is in programming mode and in a normal state

8.6.2 Display area for accumulated working time of laser

The display menu of laser cumulative working time is shown in Figure 33. It can display the cumulative startup time, cumulative laser output time, today's startup time, and today's light output time of the current laser, in units of hours, minutes, and seconds.



Figure 33 Display menu for accumulated working time of laser

8.6.3 Laser power on, mode selection, light output control area

The display area for laser power on, mode selection, and light output control is shown in Figure 34, and the display content is shown in Table 15.



Figure 34 Display area for laser power on, mode selection, and light output control

Table 15 Display content and meaning of laser power on, mode selection, and light output control display area

Display	Meaning
Main power on	Click ON to power on the main power supply; Click OFF to power off the main
Reset	clears the current laser alarm
Red light	Click ON to turn on red light; Click OFF to turn off the red light
power correction	Click ON to activate the laser power correction mode; Click OFF to turn off the laser power correction mode;
External control mode	Click ON to activate laser external control; Click OFF to turn off the laser external control; Automatic memory of mode power failure
AD mode	Click ON in to activate AD analog mode; Click OFF to turn off the AD analog mode;
Laser emission ON	Output laser
Laser emission OFF	Turn off the laser

8.6.4 Slow rise and slow fall parameter area

The display menu of the laser power ramp up ramp down parameter setting area is shown in Figure 35. Click Read Parameters to read the power rise and fall times stored in the laser. Click Set Parameters to set a new power up and down time. When the rise and fall times are all set to 0, the power ramp up and ramp down function is automatically turned off; When one is not 0, the ramp up or ramp down function is automatically turned on, and the "ramp up environment mode" indicator in the status area is lit.

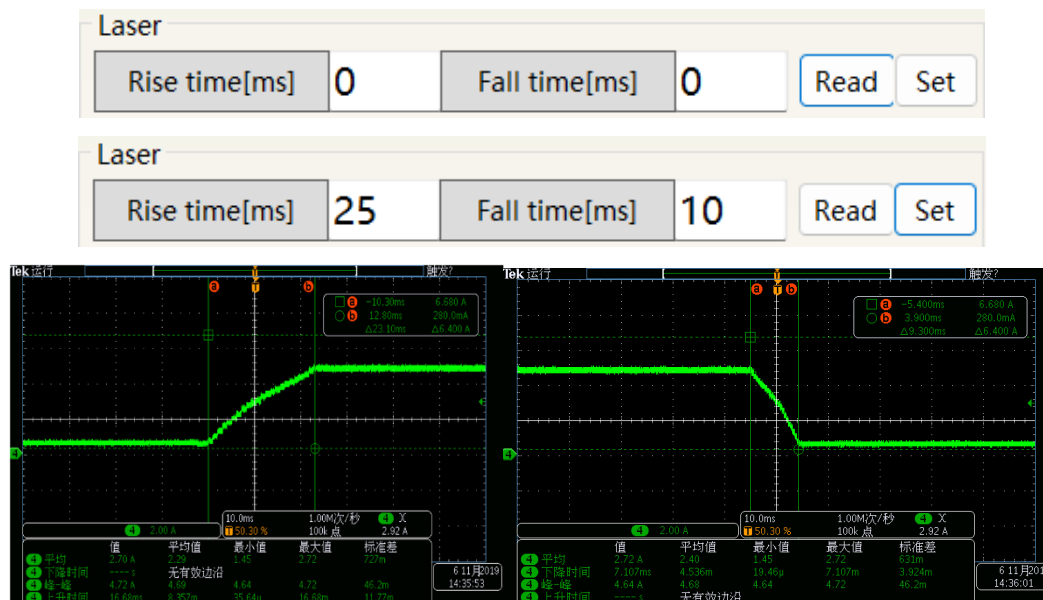

Figure 35 Display menu and measured waveform of power ramp up and ramp down setting area

8.6.5 Programming mode test area

The laser programming mode display menu is shown in Figure 36, where the program is written and written to the laser (see Section 8.13 of this description for specific methods); In this interface, select the program number, click Settings, and the "Program Mode" indicator in the status area will light up. Click "Laser Emission ON", and the "Executing" indicator in the status area will light up. After the program execution is completed, the "Executing Completed" indicator in the status area will light up. During the execution process, click "Laser Emission OFF", and the "Executing Abnormality" indicator in the status area will light up.

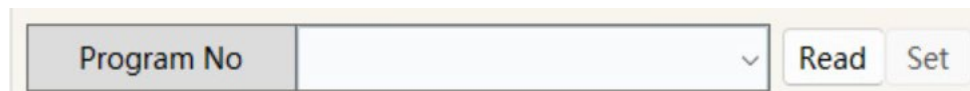

Figure 36 Laser Programming Mode Test Area Display menu

8.6.6 Output parameter reading and setting area

The display menu of the laser output parameter setting area is shown in Figure 37. The light output parameter setting is invalid when the AD mode is turned on.

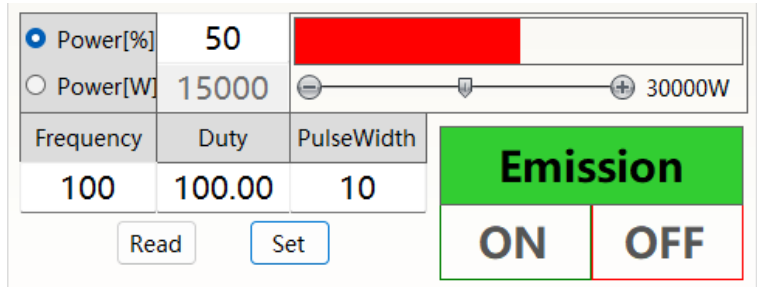

Figure 37 Display menu of light output parameter setting area

8.7 Laser circuit status display area

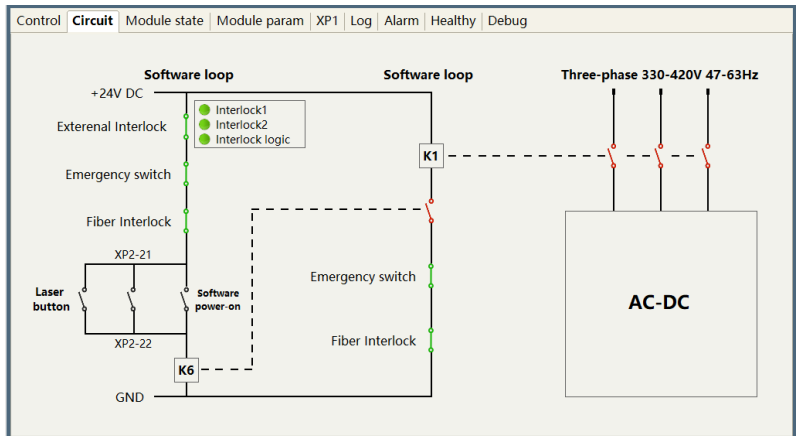

Figure 38 Laser Circuit Status Display menu

The laser circuit display area is shown in Figure 38. According to this state diagram, the laser safety circuit status can be checked.

8.8 Laser module enable display area

The display menu of the laser module enabling display area is shown in Figure 39. The green indicator light indicates that the "ON" check box is selected, indicating the module actually running in the current laser.

Module state			Module param			XP1			Log			Alarm			Healthy			Debug		
Module	State	Alarm	Module	State	Alarm	Enable	Temp1	Temp2	Module	State	Alarm	Enable	Temp1	Temp2	Module	State	Alarm	Enable	Temp1	Temp2
Master module	<input type="checkbox"/>	<input type="checkbox"/>	Optical module1	<input type="checkbox"/>	<input type="checkbox"/>	<input checked="" type="checkbox"/>	20.0	20.0	Optical module11	<input type="checkbox"/>	<input type="checkbox"/>	<input type="checkbox"/>	-	-	Optical module12	<input type="checkbox"/>	<input type="checkbox"/>	<input type="checkbox"/>	-	-
Bundle module	<input checked="" type="checkbox"/>	<input type="checkbox"/>	Optical module2	<input type="checkbox"/>	<input type="checkbox"/>	<input checked="" type="checkbox"/>	20.0	20.0	Optical module13	<input type="checkbox"/>	<input type="checkbox"/>	<input type="checkbox"/>	-	-	Optical module14	<input type="checkbox"/>	<input type="checkbox"/>	<input type="checkbox"/>	-	-
Dehumidity module	<input type="checkbox"/>	<input type="checkbox"/>	Optical module3	<input type="checkbox"/>	<input type="checkbox"/>	<input checked="" type="checkbox"/>	-5.0	-5.0	Optical module15	<input type="checkbox"/>	<input type="checkbox"/>	<input type="checkbox"/>	-	-	Optical module16	<input type="checkbox"/>	<input type="checkbox"/>	<input type="checkbox"/>	-	-
			Optical module10	<input type="checkbox"/>	<input type="checkbox"/>	<input type="checkbox"/>	-	-												
			Optical module9	<input type="checkbox"/>	<input type="checkbox"/>	<input type="checkbox"/>	-	-												
			Optical module8	<input type="checkbox"/>	<input type="checkbox"/>	<input type="checkbox"/>	-	-												
			Optical module7	<input type="checkbox"/>	<input type="checkbox"/>	<input type="checkbox"/>	-	-												
			Optical module6	<input type="checkbox"/>	<input type="checkbox"/>	<input type="checkbox"/>	-	-												
			Optical module5	<input type="checkbox"/>	<input type="checkbox"/>	<input type="checkbox"/>	-	-												
			Optical module4	<input type="checkbox"/>	<input type="checkbox"/>	<input type="checkbox"/>	-	-												

Figure 39 Display menu of laser parameter display area

8.9 XP1 Interface Status Indication

The laser interface status indication menu is shown in Figure 40, which displays the input and output status of the XP1 interface on the rear panel for easy viewing of interface status information.

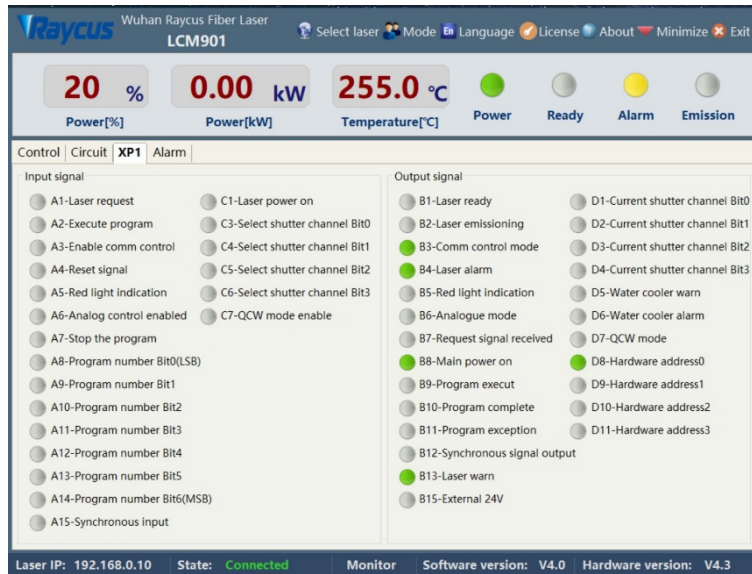

Figure 40 Interface Status Indication menu in Diagnostic Mode

8.10 Log

The laser work log display menu is shown in Figure 41. To query the laser work log, simply select the time to query and click Search.

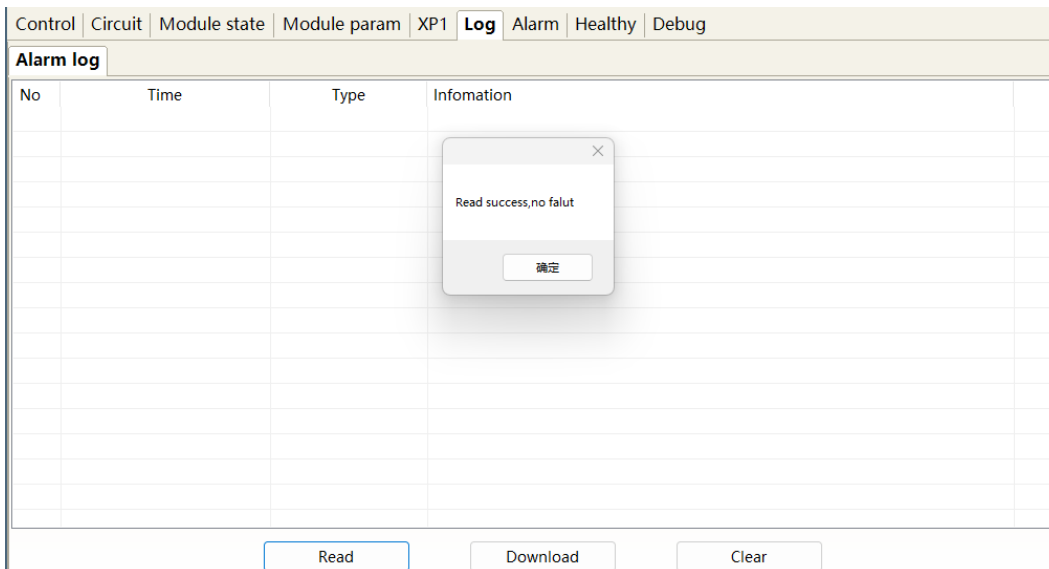

Figure 41 Laser Work Log Display menu

8.10.1 Downloading Historical Fault Records

The historical fault record download menu is shown in Figure 42.

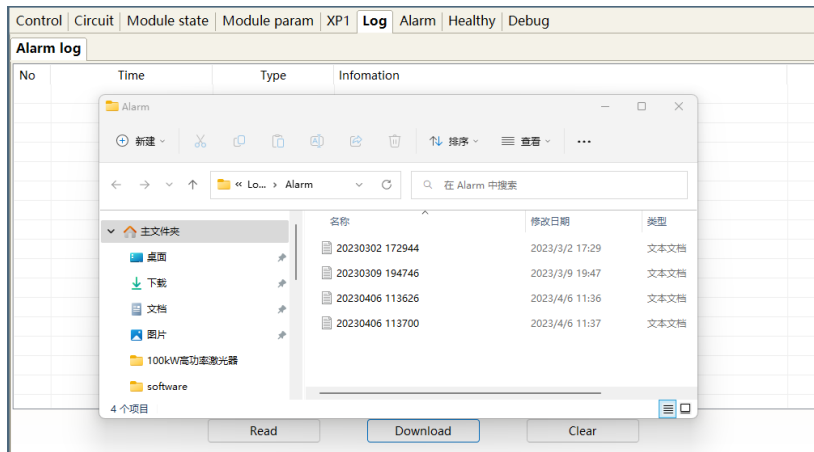

Figure 42 Download menu of laser history fault record

8.10.2 Downloaded file address

The file address query menu for all downloaded laser information is shown in Figure 43.

20230302 172944	2023/3/2 17:29
20230309 194746	2023/3/9 19:47
20230406 113626	2023/4/6 11:36
20230406 113700	2023/4/6 11:37
20230406 113734	2023/4/6 11:37
20230406 113750	2023/4/6 11:37

Figure 43 File address query menu for all downloaded laser information

8.11 Alarm Type Display Area

The display menu of the laser alarm type display area is shown in Figure 44. This menu displays the current laser alarm reason.

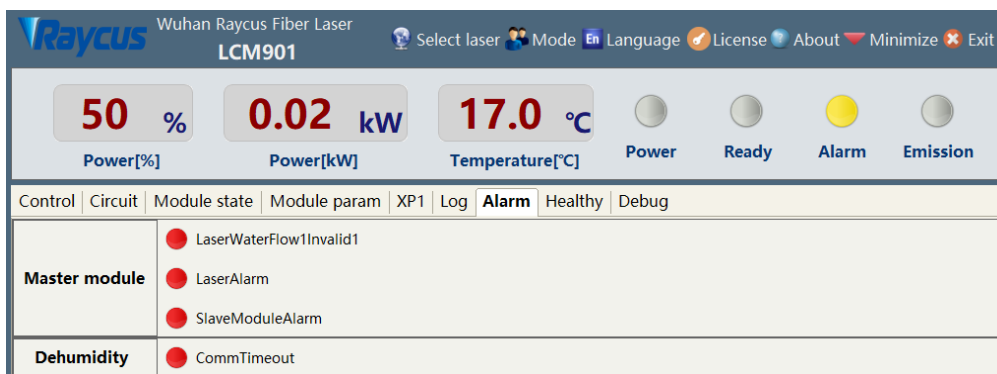

Figure 44 Display menu of laser alarm type display area

8.12 Module parameters (in diagnostic mode)

The laser enters diagnostic mode to activate the module parameter menu. The laser module parameter query menu is shown in Figure 45. This menu is for parameter query in diagnostic mode, and its data is convenient for our technical personnel to analyze the cause of laser abnormalities.

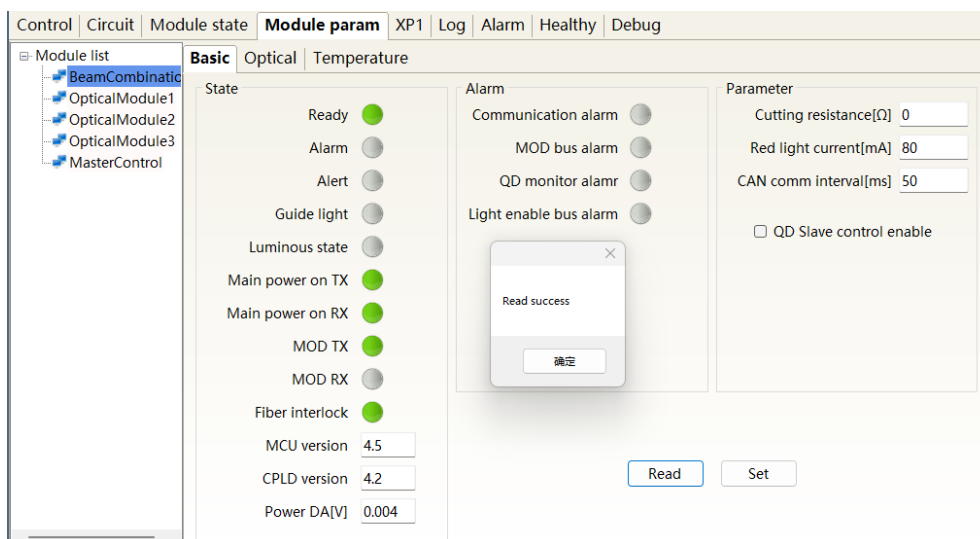

Figure 45 Module Parameter Query menu in Diagnostic Mode

8.13 Programming mode (waveform editing)

When selecting the laser operation mode, tick "Display Programming Mode" in any mode, as shown in Figure 28. The "Program Settings" interface can be activated. The laser conversion setting menu is shown in Figure 46.

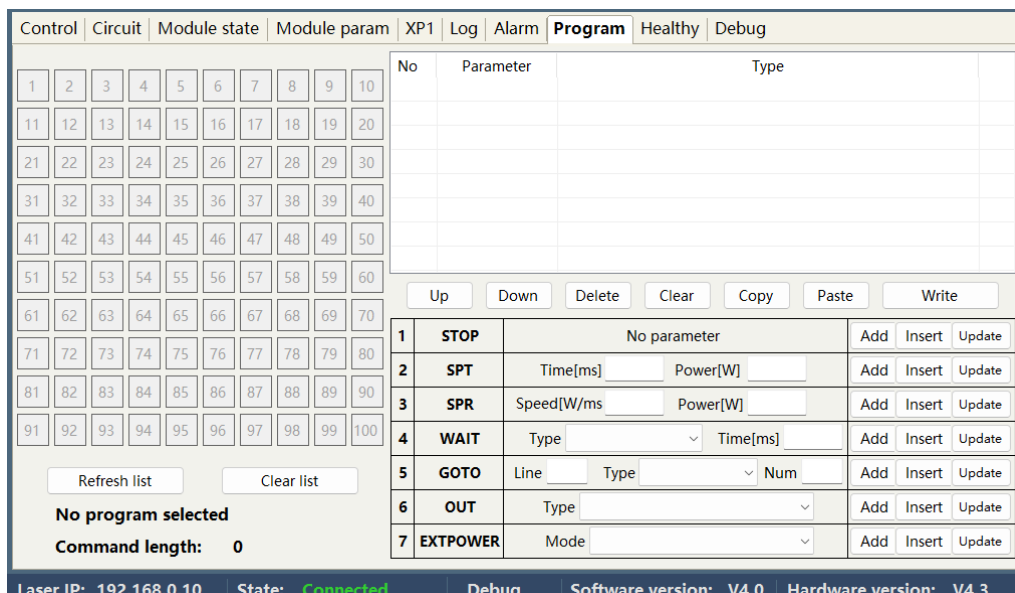

Figure 46 Programming menu in waveform editing mode

8.13.1 Viewing the number of waveform bars inside the current laser

The operation menu for viewing the number of waveform bars stored inside the current laser is shown in Figure 47. Click the "Refresh Program List" button, and the software will automatically list the number of saved waveform bars. Green indicates that this bar already has programs, and white indicates that this bar is empty.

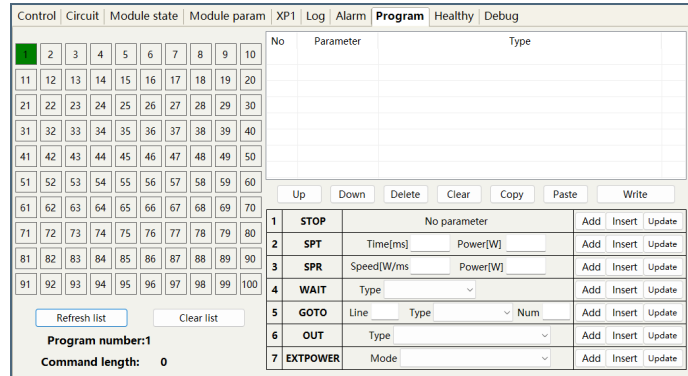

Figure 47 Operation menu for viewing the number of waveform stored inside the current laser

8.13.2 Viewing Waveform Content

The operation menu for viewing the waveform content in the current laser waveform mode is shown in Figure 48. With the left mouse button, click the waveform number to be read, and the program will automatically list the original waveform list.

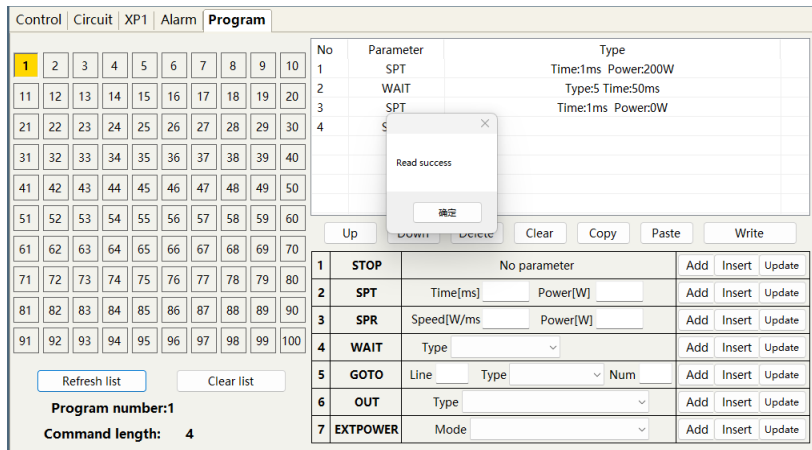

Figure 48 Operation menu for viewing the waveform content in the current laser waveform mode

8.13.3 Clear All Waveforms

The operation menu for clearing all waveforms stored in the current laser waveform mode is shown in Figure 49. Click "Clear Program List" and the software will clear all waveform stored inside the current laser.

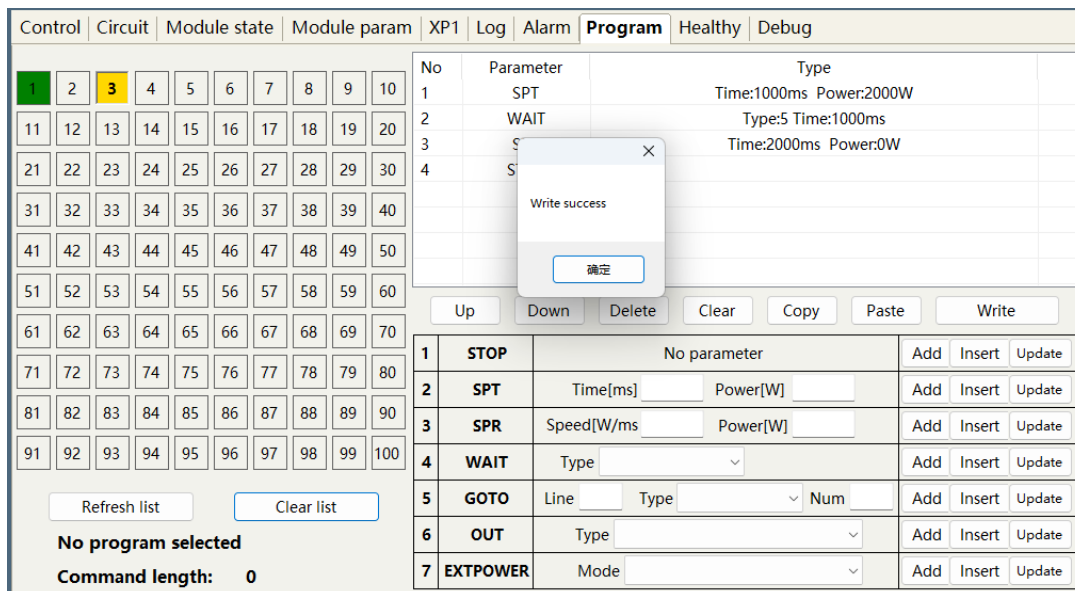
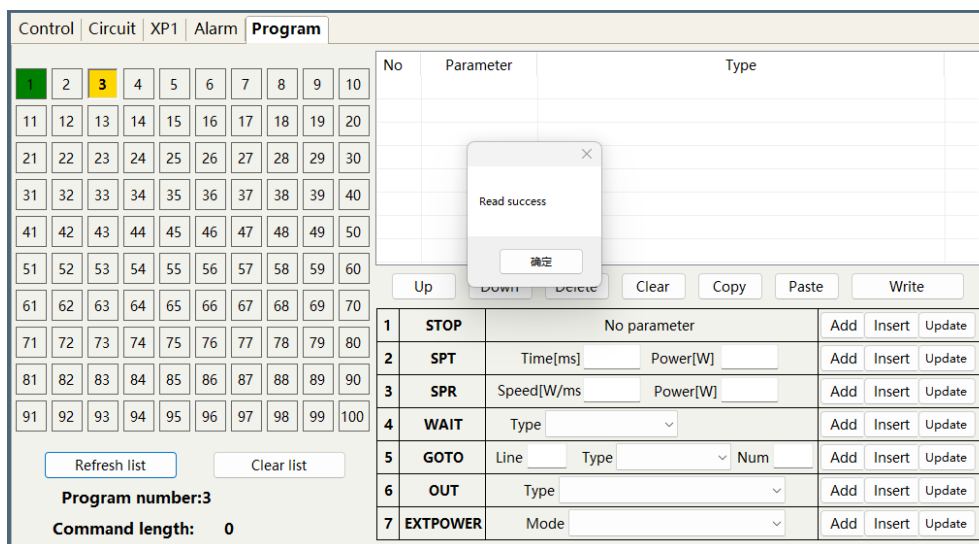

Figure 49 Operation menu for clearing all waveform stored in the current laser waveform mode

8.13.4 Editing Waveform

The steps of waveform editing when the laser is operating in waveform mode are shown in Figure 50. Step 1: Left click on the pre edited waveform number; Step 2: Select a command under the command type, enter the parameters of the command, and click "Add". The previous command immediately appears in the program list on the left; Step 3: After editing all the commands, click "Write to Laser"; Step 4: Click "Refresh Program List" again, and the new waveform number will turn green, indicating successful writing. Note: The last command of the program must be STOP.



a) Select a pre edited waveform number

No	Parameter	Type	

Up Down Delete Clear Copy Paste Write

1	STOP	No parameter	Add	Insert	Update
2	SPT	Time[ms] <input type="text" value="1000"/> Power[W] <input type="text" value="2000"/>	Add	Insert	Update
3	SPR	Speed[W/ms] <input type="text"/> Power[W] <input type="text"/>	Add	Insert	Update
4	WAIT	Type <input type="text"/> Time[ms] <input type="text"/>	Add	Insert	Update
5	GOTO	Line <input type="text"/> Type <input type="text"/> Num <input type="text"/>	Add	Insert	Update
6	OUT	Type <input type="text"/>	Add	Insert	Update
7	EXTPOWER	Mode <input type="text"/>	Add	Insert	Update

No	Parameter	Type	
1	SPT	Time:1000ms Power:2000W	

Up Down Delete Clear Copy Paste Write

1	STOP	No parameter	Add	Insert	Update
2	SPT	Time[ms] <input type="text"/> Power[W] <input type="text"/>	Add	Insert	Update
3	SPR	Speed[W/ms] <input type="text"/> Power[W] <input type="text"/>	Add	Insert	Update
4	WAIT	Type <input type="text"/> Time[ms] <input type="text"/>	Add	Insert	Update
5	GOTO	Line <input type="text"/> Type <input type="text"/> Num <input type="text"/>	Add	Insert	Update
6	OUT	Type <input type="text"/>	Add	Insert	Update
7	EXTPOWER	Mode <input type="text"/>	Add	Insert	Update

b) Add Command Type

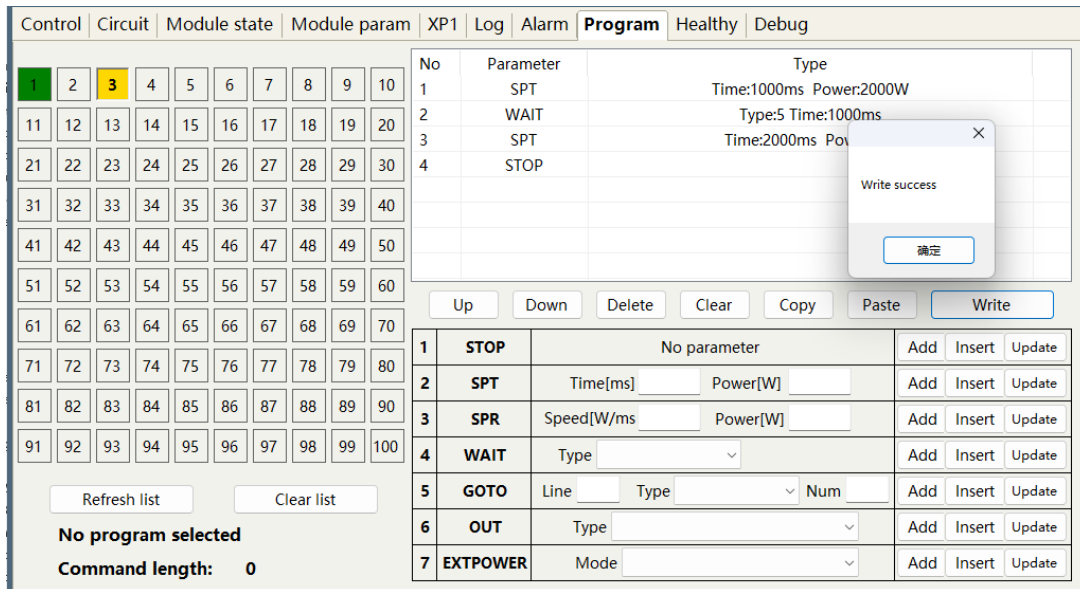

c) Write commands to the laser

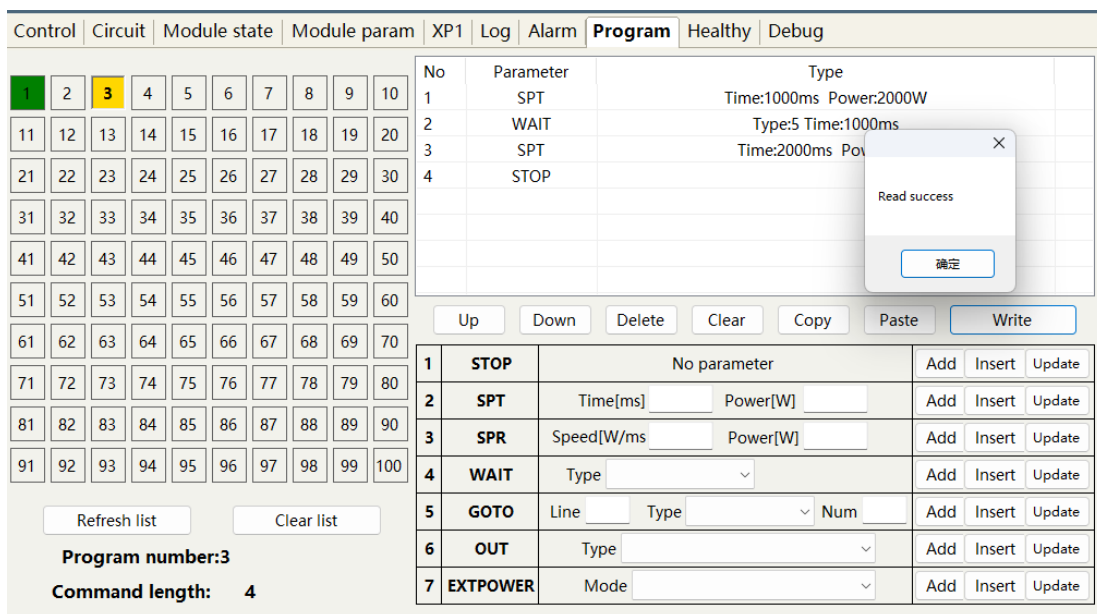

d) Check whether the command was successfully written

Figure 50 Schematic diagram of waveform editing operation in waveform mode

8.13.5 Command Interpretation

The meaning of all commands and commands during laser operation is shown in Table 16.

Table 16 Commands and their meanings during laser operation

Command Code (1 byte)		Parameter 1 (2 bytes)		Parameter 2 (4 bytes)		Description
1	Stop	/		/		Stop has no command to end without a program, and the last command of each program must be this command
2	SPT	0~65000 (ms)		0~65000(W)		takes time for parameter 1 to change power to parameter 2
3	SPR	0~65000 (W/ms)		0~65000(W)		Change the power to parameter 2 at the power change rate of
4	WAIT	1	WAIT 1 waiting for synchronization signal low level	/		
		2	Wait for synchronization signal high power level	/		
		3	Waiting for the rising edge of the synchronization signal	/		
		4	Wait for the synchronization signal to fall along the space	/		
		5	Waiting time	0~65000ms(int)		
5	GOTO	0~99	line	-1	When the synchronization signal is low	the jump condition is met, and the jump is to another line number
		0~99	line	-2	Jump when sync signal is high	Jump to other line numbers when conditions are met
		0~99	line	0~1000000	Number of times to jump to this line number	Number of times to cycle to this line number

6	OUT	1	SO	1	Output synchronization signal low level	
---	-----	---	----	---	---	--

				2	Output synchronization signal high	
7	EXT Power	1	0~10V			
		2				

9 Warranty, Repair and Return

9.1 General Warranty

After all the lasers manufactured according to the standard or non-standard model production documents are shipped, Raycus guarantees the products with material and technical problems and guarantees that they meet the specifications under normal use.

Raycus has the right to selectively repair or replace any product that has a material or technical problem during the warranty period. All products repaired or replaced during the warranty period only provide free warranty services for products with special problems. Raycus reserves the right to collect payment for products that have problems under normal use.

9.2 Limitations of Warranty

The warranty does not cover the maintenance or reimbursement of our product of which the problem results from tampering, disassembling, misuse, accident, modification, unsuitable physical or operating environment, improper maintenance, damages due to excessive use or not following the instructions caused by those who are not from Raycus. The customer has the responsibility to understand and follow this instruction to use the device. Any damage caused by fault operating is not warranted. Accessories and fiber connectors are excluded from this warranty.

According to the warranty, client should inform us within 31 days after the defect is discovered. This warranty does not involve any other party, including specified buyer, end-user or customer and any parts, equipment or other products produced by other companies.



WARNING: It is the customer's responsibility to understand and follow operating instructions in this User Guide and specifications prior to operation-failure to do so may void this warranty. Accessories and fiber connectors are not covered by this warranty.

9.3 Service and Repair

Do not open the device. There are no user serviceable parts, equipment or assemblies for user in this product. All service and maintenance shall be performed by qualified Raycus personnel.

Please contact Raycus as soon as possible when problems under warranty about maintenance happened to the product.

The product returned with permission should be placed in a suitable container.

If any damage happened to the product, please notify the carrier in document immediately.

Raycus reserve the right to make changes in design or constructions of any of our products at any time without incurring any obligation to make changes or install the same on units previously purchased.

All the items within warranty and service above provided by Raycus are for uses' reference; formal contents about warranty and service are subject to the contract.

Information contained in this document is subject to change without notice.

©2024 Wuhan Raycus Fiber Laser Technologies Co. Ltd., All Rights Reserved.